

ROTHBUCHER SYSTEME

RS09

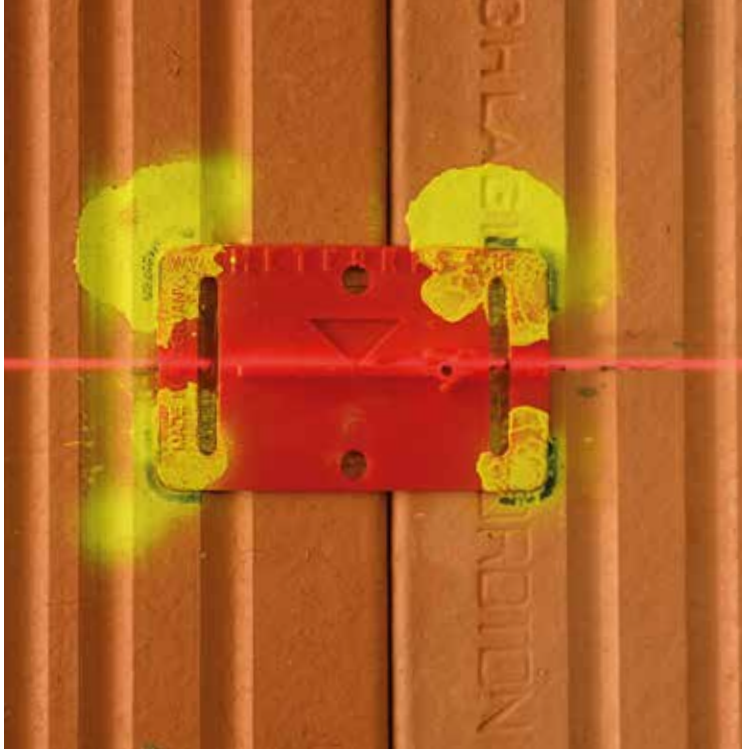

The RS Surveying Accessory System

Smart Surveying Solutions – Perfect for BIM and the Digital Construction Site
Request our Price List



Since 1996, the Rothbucher Systems Company has developed and sold products for the documentation of surveying points on construction sites. Since then, our products have been used very successfully in the field of construction surveying and monitoring.

High-precision instruments are indispensable to meet the high demands in surveying today. Therefore, pencil strokes, nails and other unidentifiable markers should be a thing of the past because they do not comply with the needs of modern surveying.

Precision starts with the surveying points. Only then can precision surveying instruments yield the expected results. This is also why our products are so much appreciated by surveyors, site managers, foremen and architects and now set a worldwide standard at many building sites.

Our system **“One reference point for all instruments”** was received with a flood of interest by the market. The system convinces with innovative solutions and easy handling. It sets new standards for reference points not only for the Digital Construction Site and BIM but also on all construction sites where modern surveying instruments are in use.

On our website www.smart-targets.com and on our **Rothbucher Systems YouTube channel*** we show a wide range of solutions and examples of use.

We are pleased to show you the versatility of our surveying accessory system in our new catalogue. On the following pages, you will surely also find the right product for your current project or suitable products to supplement your surveying instrument.

If you have any questions, please do not hesitate to contact us.



Georg Rothbucher

Founder and owner of Rothbucher Systems

















*RS YouTube Kanal

Content – 1 of 3

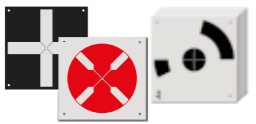
	Datum and Axis Markers RS10 and RS11	6 - 7
	Datum and Axis Markers RS20 and RS21	8 - 9
	Reflective Targets RSZ2 - RSZ6, RSZ22, RSZ2YE - RSZ6YE	10 - 11
	BIM Construction Targets RS30 to RS41	12 - 13
	Smart Targets RS50 to RS71	14 - 15
	Smart Targets RSAKZ6 Aluplate RSALU22	16 - 17
	Smart Angle Targets RS80, RS90 and RS100	18 - 19
	Angled Adapters RSAK80 and RSAK130	20 - 21
	Targets with clip system for recoverable reference points RSAM80 and RSAMG80	22 - 23
	Reflective Target with tilt function RS183	24 - 25
	Target Markers with swivel and tilt function RS192M with target, RS193 and RS193M with reflective target	26 - 27
	Stake Out Aids for Total Stations RS95, RS96 and RS97	28 - 29
	Stake Out Aid for Robotic Total Stations RS150M	30 - 31
	Mini Prisms RSMP10, RSMP12 and RSMP15	32 - 33

Content – 2 of 3

	Mini Prisms with tilt function RSMP380 and RSMP380M	34 - 35
	Mini Prisms with swivel and tilt function RSMP390 and RSMP390M	36 - 37
	Mini Prisms 220° RSMP480 and RSMP490M	38 - 39
	Laser Scanner Targets RSL301, RSL322 and RSL496	40 - 41
	Laser Scanner Targets RSL-X80 and RSL-X90M	42 - 43
	Mobile Mapping-, Scanner- and Drone Targets RSL-X94M and RSL-X95M	44
	Laser Scanner and Drone Sign RSL402	45
	Laser Scanner Targets with swivel and tilt function RSL420M and RSL422M	46 - 47
	Laser Scanner Sphere magnetic RSLB10M Laser Scanner Sphere with suction cup RSLB10SV	48 - 49
	Laser Scanner- and SLAM Targets RSL430 and RSL452M	50 - 51
	Ground Control Targets for Drones RSL510 and RSL512, RSL520 and RSL532, RSL570	52 - 53
	Ground Control Targets for Drones, unfoldable RSL512XL and RSL532XL	54 - 55
	Drone Targets RSL580 and RSL590M	56 - 57
	Boundary Markers RSKM10 to RSKM40 Fixed Point RSFP1 and Protection Cap RSFP1-A	58 - 59

Content – 3 of 3

	Track Machine Targets TMT10, TMT20, TMT25 and TMT30	60 - 61
	Laser Target, foldable RSLT10	62
	Fixed Point System Series X80 RSFP-X80, RSMS1033 and RSSV-X80	63
	Fixed Point System Series RSFP-X80 – Overview Fixed Point System Series RSFP-X90 – Overview One Fixed Point for all instruments	64 65 - 67
	Fixed Point System Series X90 RSFP-X90, RSFP-X90-1+3, RSFP-X90-2	68
	Fixed Point System Series X90 RSFP-X90-5, RSFP-X99-5, RSFP-X90-20+21, RSFP-X99-20+21	69
	Fixed Point System Series X90 RSFP-X90-25+26, RSFP-X99-25+26, RSFP-X90-30 to 39	70
	Fixed Point System Series X90 RSSV-X90, RSSV-X99, RSFP-X98	71
	Fixed Point System Series X90 RSFP-X99, RSFP-X99-11+12, RSFP-X90-S40	72
	Adapters and other Accessories Construction Glue RSMK-FIX	73 - 75
	Suitcase-Sets with prisms or reflective targets KS1-390M+ and KS1-193M+	76
	Suitcase-Sets with Laser Scanner- or SLAM targets KS2 and KS2-2, available for RSL420M, RSL422M and RSL452M	77



Ideal for concrete construction sites without plastering work and for permanent securing of axis as a negative imprint in concrete.



The negative imprints become visible on the ceiling after removing the ceiling formwork.

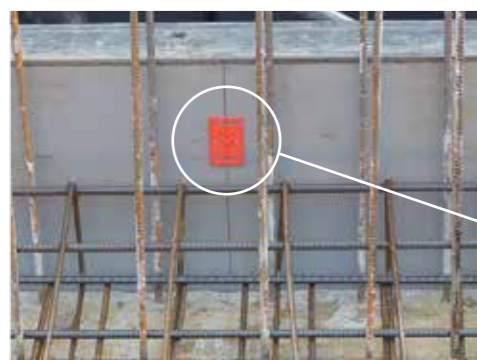

Datum and Axis Markers RS10 and RS11*



The markers RS10 and RS11* are used to secure survey points on construction sites without plastering work and in door or window reveals.

To secure axis permanently until the building is completed, the markers are already measured and fastened in the slab formwork or the slab edge formwork on axis. The negative imprints, which are clearly visible for all trades, are used for the dry wall construction and any further inside installations.

The foreman uses the negative imprints at the ceiling edge to transfer the axis right to the freshly concreted ceiling with a string (chalk line) or laser. If required, they can later be used to install the façade.

Datum and axis markers from Rothbucher Systems have been standard on many construction sites worldwide for years.

Datum and Axis Markers RS10/RS11*

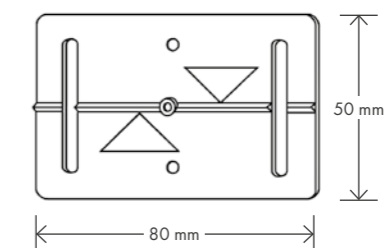

* self-adhesive

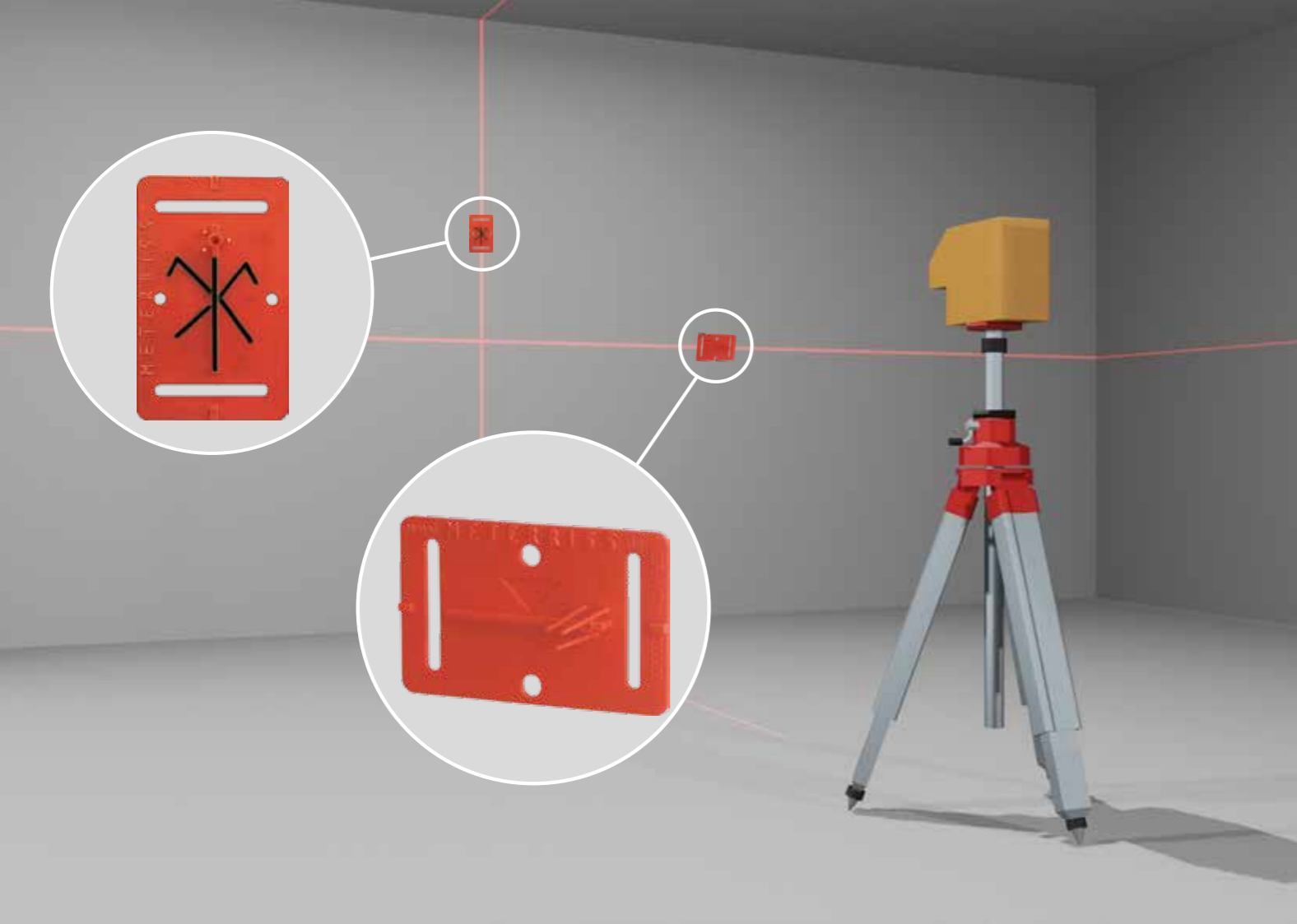

Datum and Axis Markers RS20 and RS21*



The markers RS20 and RS21* are installed on an unplastered or unrendered wall to provide an unambiguous and clear datum such as Finished Floor Level to all tradesmen.

To avoid measurement differences when transferring, the markers have a protrusion to which a ruler can be applied.

The elastic "stubs" ensure that the datum is stable and visible until after plastering and easy to find again. Heights and axes are also secured until plastering work is complete.

After completing all the works, the flexible "stubs" are easily pinched off, and only little work has to be done for refinishing. The markers remain under the plaster as proof.

In order to avoid possible manipulations, the corners are sprayed over in color, so that a wanton relocation of the marks is immediately recognizable.

We recommend gluing the markers and securing them at least once.

For secure marking of datum and axes on building sites with plasterwork.

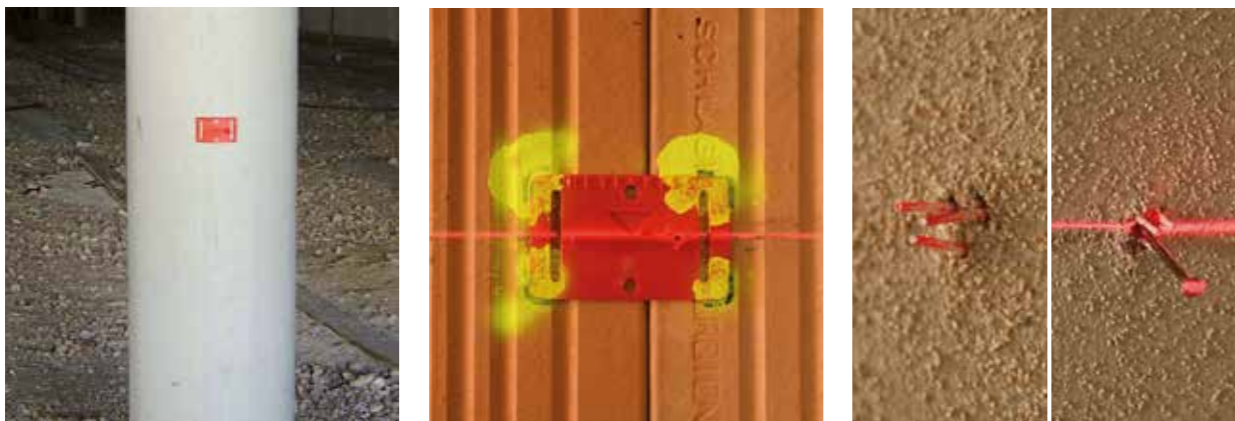

RS21r* fixed to a column. The protrusion is cut in 4 - 5 times with a carpet knife.

RS21r* glued, fastened, and sprayed over with colour to prevent tampering.

Elastic "stubs" to permanently ensure surveyed measurements are securely marked until after plastering work.

Datum and Axis Markers RS20 and RS21*

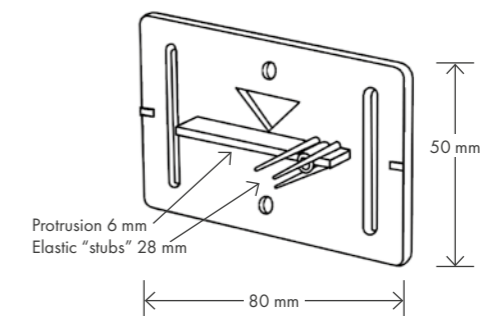

* self-adhesive

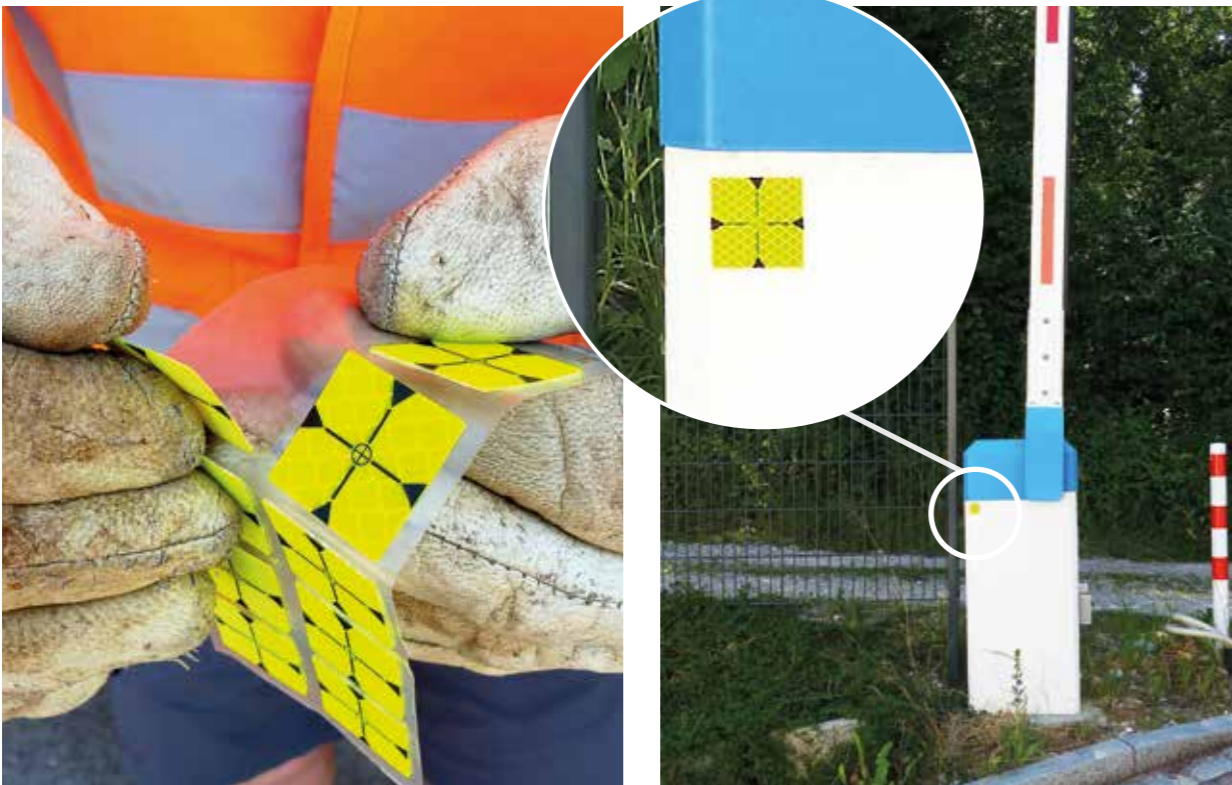

Gutters are not recommended for attaching reference points, as they are often unstable and narrow curves also have a negative effect on the accuracy of the measurement.

Reflective Targets RSZ2 - RSZ6, RSZ22, RSZ2YE - RSZ6YE

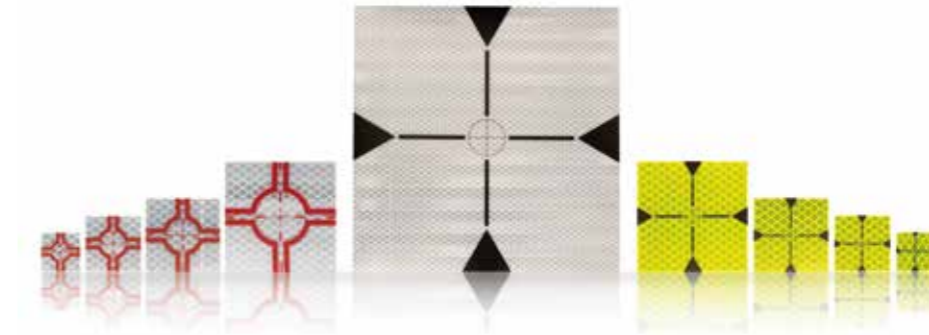

Reflective targets are available in the following sizes:

RSZ2 / RSZ2YE	21 x 21 mm	→ Range approx. 50 m
RSZ3 / RSZ3YE	30 x 30 mm	→ Range approx. 80 m
RSZ4 / RSZ4YE	40 x 40 mm	→ Range approx. 100 m
RSZ6 / RSZ6YE	60 x 60 mm	→ Range approx. 120 m
RSZ22	220 x 220 mm	→ Range approx. 500 m

The ranges are average values and will be exceeded when using most current surveying instruments. A minimum distance of 10 m is required for some instruments.

Our reflective targets are supplied on a foil backing. Removal of the targets from the backing is possible even if wearing gloves!

In order to guarantee precise measurements with reflective targets with an accuracy of 1-2 mm, the angle of view to the targets should be no more than 25°. For all distance measurements using a total station, it is recommended that only markers with reflective targets are used!

Especially for use with levels, theodolites and general construction lasers, we offer markers with crosshairs without reflective targets.

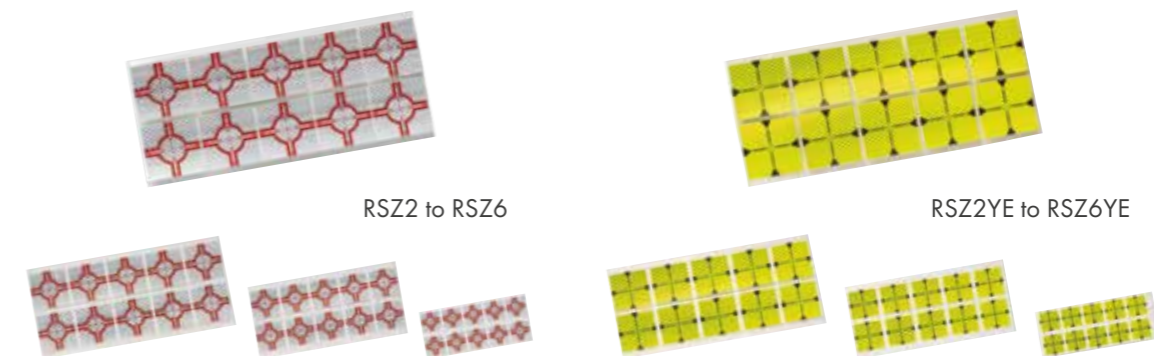



RS30r in industrial construction: documentation of heights and axes in one product.



RS30r in industrial construction: a perfect measuring point for each measuring instrument.

The height, axis and position number are indicated with number punch or water proof marker pen.



BIM Construction Targets RS30 and RS31*

RS40 and RS41*

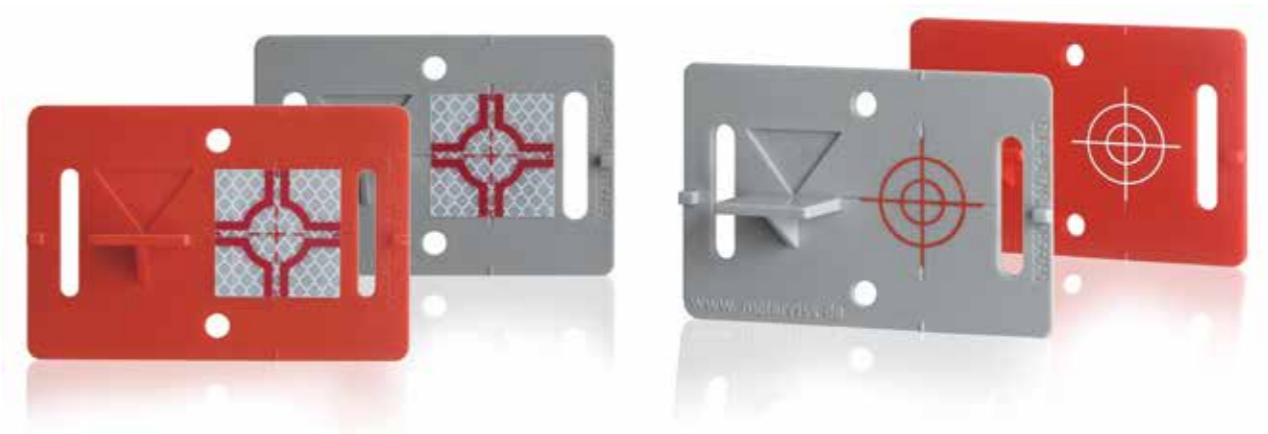

Perfect reference points for BIM (Building Information Modeling)

→ **Unmistakable fixed points for all trades**

→ **A fixed point for all surveying instruments currently used!**

The targets RS30 and RS40 permit documentation and permanent security of heights and axes with a single product. If different measuring devices are at a construction site, the BIM targets are the best solution to avoid measuring differences.

No matter if levelling instrument, laser, theodolite or total station are in use, these targets are the perfect surveying point with identical heights and coordinates for any instrument!

On difficult surfaces, the markers are permanently fastened with adhesive or with plugs and screws. A protrusion where a meter ruler or measuring rod can be placed guarantees the exact measurement of the height.

Crosshairs are imprinted on the backing plate under each reflective target to ensure the survey point is durably marked. Should the reflective target be damaged, its replacement is no problem. There is thus no loss of the original survey point and the uniqueness and durability of the survey point in accordance with BIM are guaranteed.

BIM Construction Targets RS30 & RS31*
with reflective target 30 x 30 mm

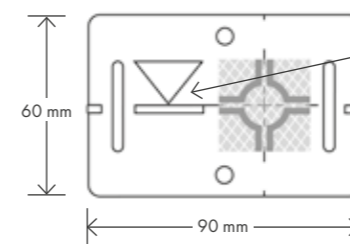

BIM Construction Targets RS40 & RS41*
with crosshair

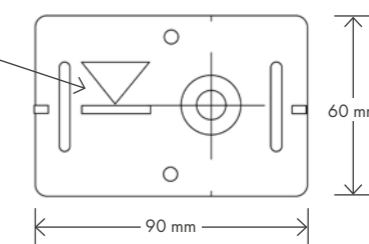

* self-adhesive

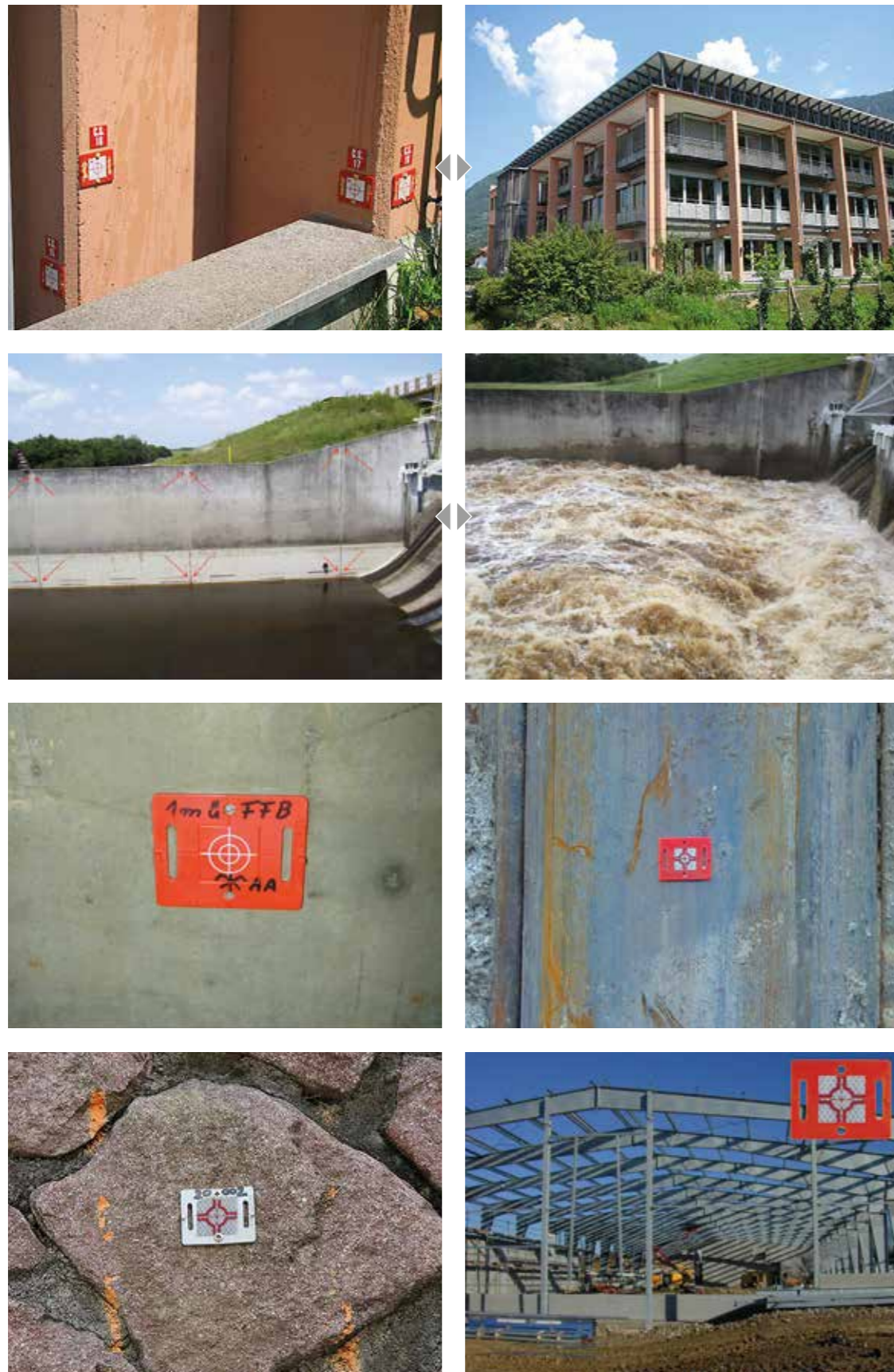

Smart targets for diverse applications

Smart Targets

RS50 / RS51*

RS60 / RS61*

RS70 / RS71*



These markers offer very high flexibility in use and they also meet all requirements for their use on BIM-compliant construction sites.

Outside they can be fastened permanently to any desired point. There they are mostly used for positioning with total stations or for monitoring. Inside buildings, heights and axes are clearly documented. The transfer of axes to the next floor can be done easily and accurately by means of laser or plumb line to stairwells or other openings.

If the markers are fastened to the façade, surveyors and foremen can continue to use them during construction. Uses by façade subcontractors include the measurement of glass or natural stone façades. The material and texture of the markers make them ideal for the long-term observation of buildings, bridges, retaining walls and much more.

Crosshairs are imprinted on the backing plate under each reflective target to ensure the survey point is durably marked. If the reflective target is damaged at any point, it can easily be replaced and the original survey point can be restored quickly, easily and cheaply.

Smart targets RS50/51*
with reflective target
30 x 30 mm

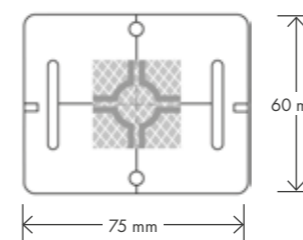

Smart targets RS60/61*
with reflective target
40 x 40 mm

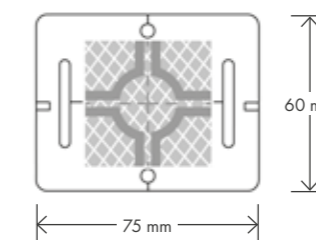

Smart targets RS70/71*
with crosshair

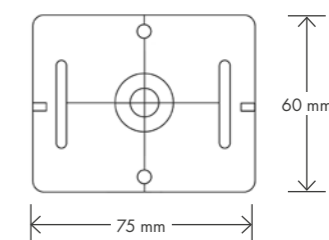

* self-adhesive



Arabtec Resident Tower
Dubai



Highway bridges A94

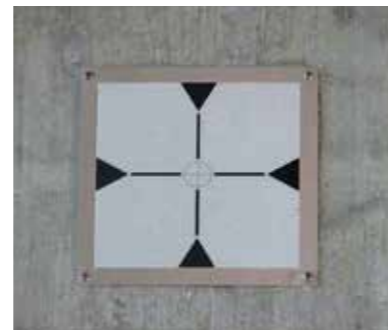

Schellingwoude Bridge
Amsterdam



Highway bridges A8



Smart Target RSAKZ6



Aluplate RSALU22

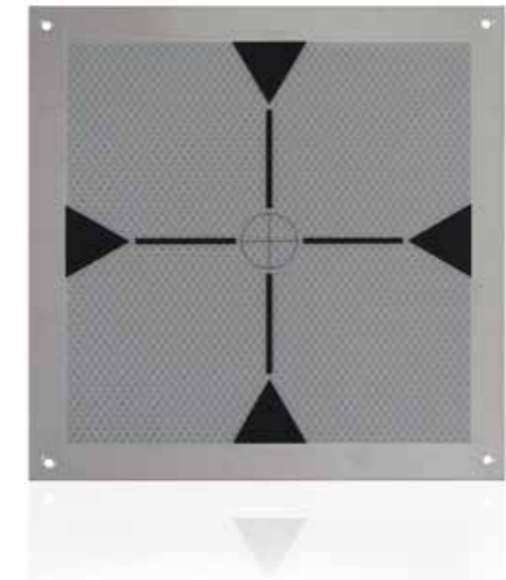

High-Precision across large distances

The smart targets RSAKZ6 and RSALU22 are always used where surveying is to be carried out over longer distances.

The RSAKZ6 targets are fitted with 60 x 60 mm reflective targets and the range is approx. 120 m up to 250 m and more in reflectorless mode.

The reflective target panels RSALU22 with aluminum panel 260 x 260 mm and reflective 220 x 220 mm targets for measurements up to 500 m.

RSALU22 – Aluplate
with reflective target 220 x 220 mm

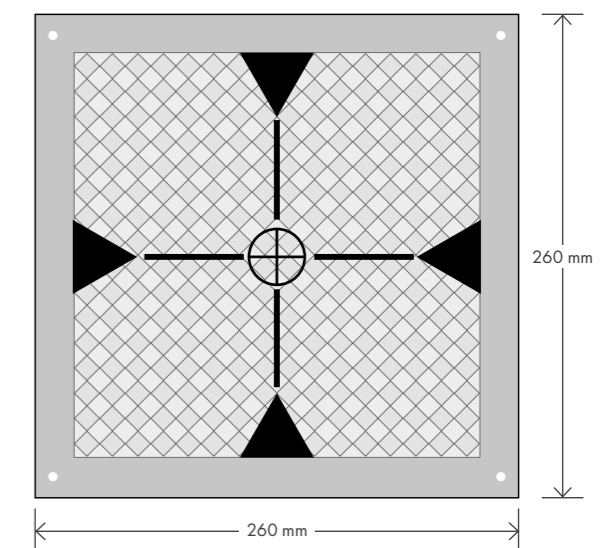

RSAKZ6 – Carrier plate
with reflective target 60 x 60 mm

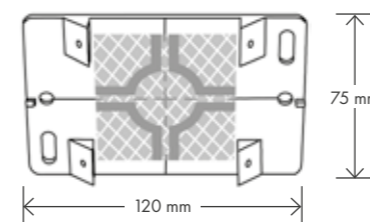



Subway Station, World Trade Centre in New York City



RS90r, Subway Station, World Trade Centre



RS90g, Metro Rotterdam



RS80r, Al Sadd Stadium in Qatar



Al Sadd Stadium in Qatar

Smart Angle Targets

RS80

RS90

RS100

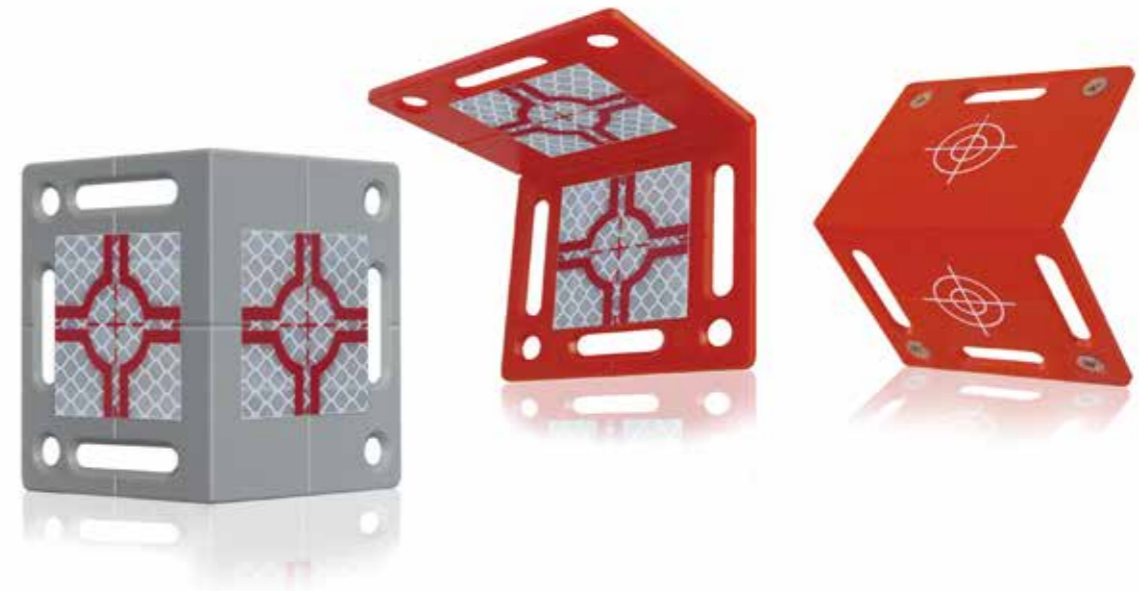

Solutions for difficult positions

These markers are used wherever difficult surveying positions would make it impossible to sight the measuring points.

The RS80 markers are installed in "roof-shape". For the observation of façades and objects, these targets are very well suited as a corner solution. If heights and axes are to be transferred from outside to inside or vice versa, the markers can be mounted, for example, on the window reveal. You can then literally measure around corners.

The RS90 markers, permit sighting on the surveying points from almost any position. For example, an axis, can be sighted from the front, below or above.

To ensure that the survey point can be secured over a long period, crosshairs are imprinted on the base plate under each reflective target.

Smart Angle Target
RS80 with two reflective targets
40 x 40 mm

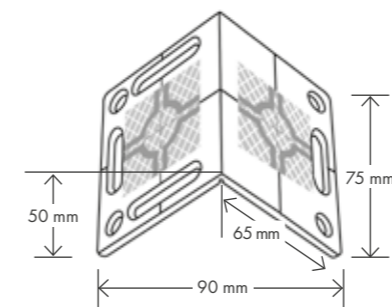

Smart Angle Target
RS90 with three reflective targets
40 x 40 mm

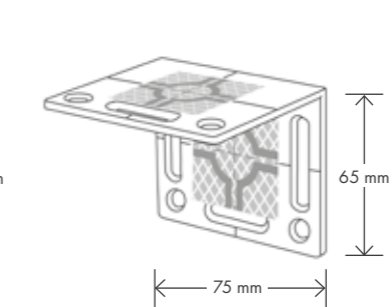

Smart Angle Target
RS100 with four crosshairs
40 x 40 mm

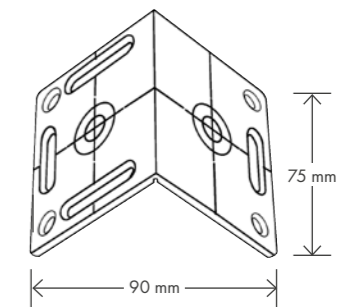



Monitoring on railway tracks. Easy fixing is guaranteed with our construction glue RSMK-Fix.

Angled Adapters RSAK80

RSAK130

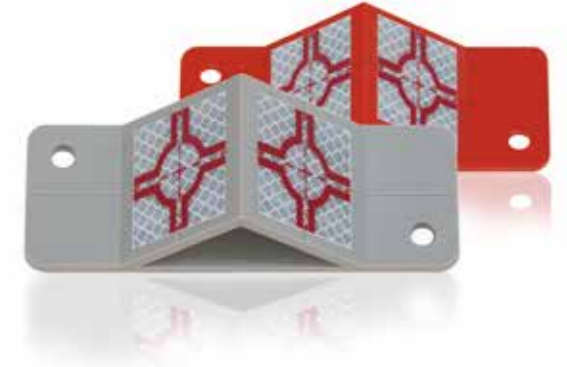

RSAK80 and RSAK130 are often used on rail tracks, bridges, enclosures, dam walls, buildings, supports, high warehouse shelving, in lift shafts e.t.c. With well planned installation, the survey point can be sighted from almost any position with these products.

On railway tracks, for example, the surveyor no longer needs to put himself in danger, but can perform his measurements from a safe position at any time. Dangerous and expensive road closures are also no longer necessary, many survey measurements are significantly simplified.

In lift shafts the adapters are mounted to the axis in a vertical line (see illustration on the left). In this way, the axes are clearly visible from any position for all trades.

Crosshairs are imprinted on the backing plate under the exact center of each reflective target to ensure the survey point is durably marked.



Surveyors no longer need to enter danger areas.

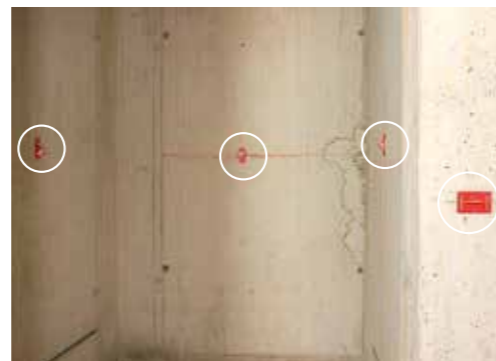

RSAK130 and RS21: perfect reference points for FFL and axes in the area of elevator shafts



Observation of sound barrier walls



Observation of bridges

**RSAK80 – Carrier Plate
with reflective targets 40 x 40 mm**

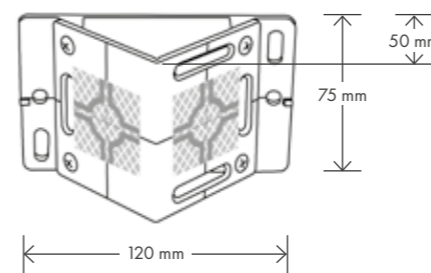

**RSAK130 – Plate with angle and
2 reflective targets 30 x 30 mm**

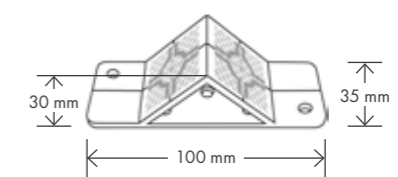



The Targets with the Magic Clip
RSAM80 **RSAMG80**



V4A stainless steel adapter

The markers are available with the RS clip system for securing reference points over decades. Points that become unusable due to weather or damage can be quickly and inexpensively re-stored **without losing the original survey point!**

The adapters are available with or without a DW15 thread. Depending on the requirements and duration of the planned use, the parts are glued on, welded on or screwed into existing anchor sleeves.

This means on bridges where anchor sleeves are installed in the cantilever arm the markers can for example be screwed into the existing anchor sleeves and used for monitoring bridges. On new supports and walls, anchor sleeves are included where necessary in appropriate places to ensure monitoring after buildings are completed.

The resulting reference points are hard to beat for durability!

You can find further solutions for measurements over a longer period with larger distances and even greater precision on pages 65 to 72.



Survey point on the ski lift support



Coen Tunnel Amsterdam



Bridge monitoring (Tappen Zee Bridge USA)

Adapter RSAM80
with reflective targets 40 x 40 mm

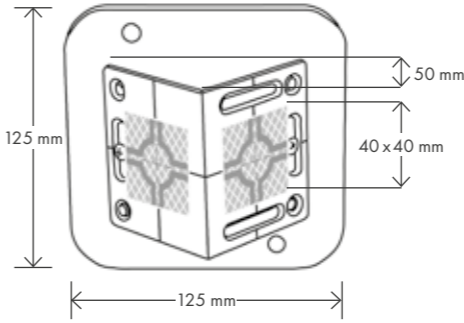

Adapter RSAMG80 with DW15 thread
with reflective targets 40 x 40 mm

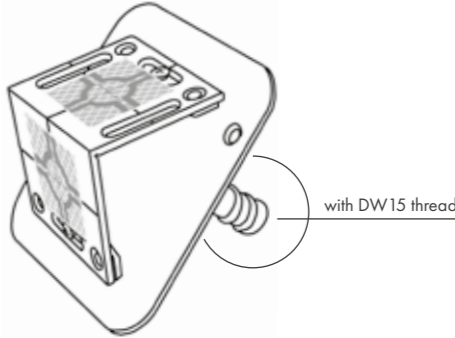

Reflective Target with Tilt Function RS183



When using total stations, the reflective target can always be aligned precisely with the measuring instrument. The target can be turned through an angle of 180°, making it possible to use the same survey point from different directions. Used in combination with our mounting plate RSFP-X80, the targets can be clicked in into two different orientations, enabling it to be sighted from almost any direction (see illustrations at left).

If the targets are mounted around the site before the start of construction, the foreman and surveyor can always use the same survey point from initial trenching work up to the top floor. Depending on the construction phase, the markers are adjusted to the construction site progress by alignment of the reflective target.

With the integrated plug-in system, several targets can be combined with each other. The targets can be combined in both directions, enabling surveying from different directions without needing to rotate the reflective targets. The spacing of the survey points between the combined markers is always 60 mm.

Mounting adhesive permits quick and simple installation even on difficult surfaces. Fixing holes permit fastening with plugs and screws.

RS183 with reflective target 30 x 30 mm

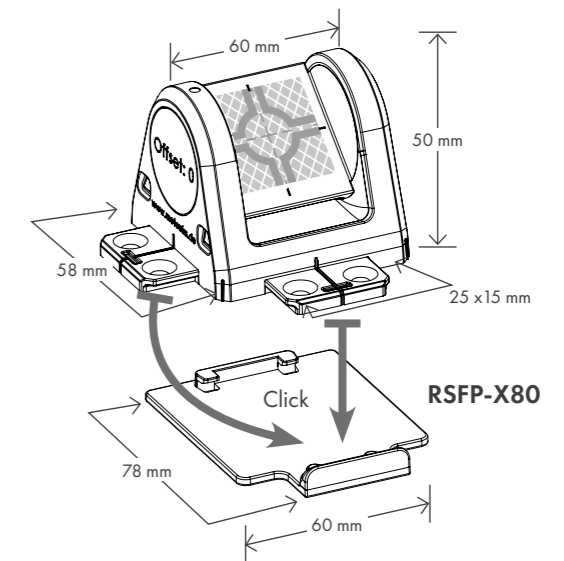

Offset: 0
Tilting axis height: 30 mm



RS183 on mounting plate RSFP-X80g for simple and fast mounting on any base. Simply click out, turn and click in again to survey in both horizontal and vertical orientations with the same survey point.



RS193M* with fixed point RSFP-X90 on the batter board. In this case the fixed point rotates exactly on the axis.

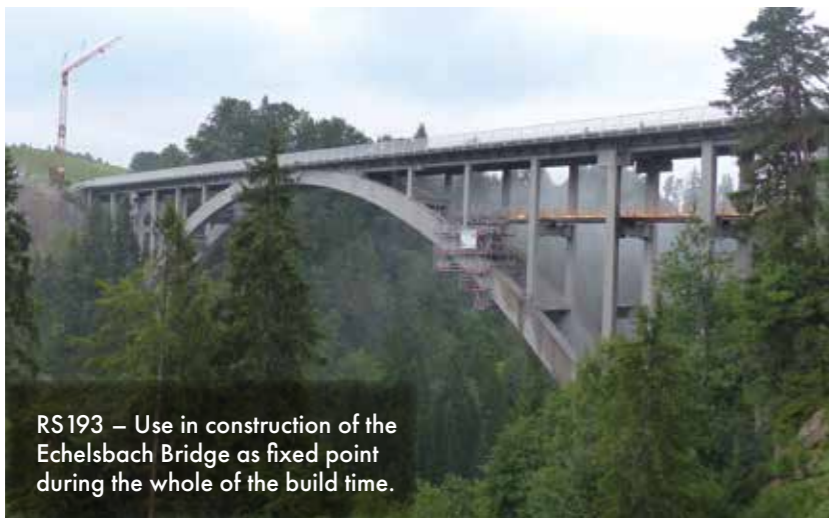

RS193 – Use in construction of the Echelsbach Bridge as fixed point during the whole of the build time.



Example of the use of RS193M* as a fixed point on different surfaces and for the exact alignment of the drill carriage.

Target Marker RS192M*

Reflective Targets RS193 and RS193M*



See pages 65/66
**FIXED POINT
SYSTEM**
RSFP-X90

NEW
SUITCASE SET
KS1-193M+
Page 76

Target markers and reflective targets with swivel and tilt function

The reflective targets RS193 and RS193M* can be rotated through 360° and always aligned precisely with the surveying instrument. The same survey point can thus be used from all directions.

When using a fixed point of the fixed point system RSFP-X90 to RSFP-X99, the targets RS192M* and RS193M* can be removed and later replaced on the same survey point – see pages 65 to 72.

The RS192M* targets are used for positioning and surveying with the following instruments:
Leica 3D Disto, GeoMax Zoom 3D and Flexijet 3D.

If required, the specially developed protective cap RSPC20 protects the targets from the weather and soiling.

RS192M* with target marker 20 x 20 mm
RS193 and RS193M* with reflective target marker 30 x 30 mm

Range approx. 80 m
Offset: 0
Tilting axis height: 45 mm

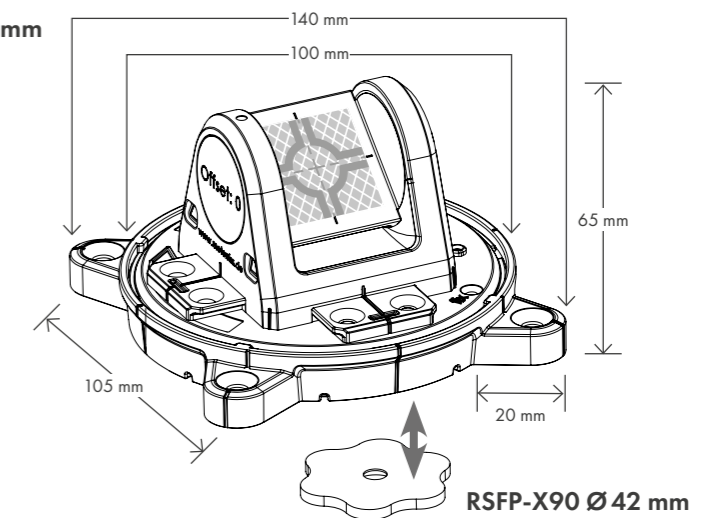

* magnetic



RS95 – Stake out work on the batter board

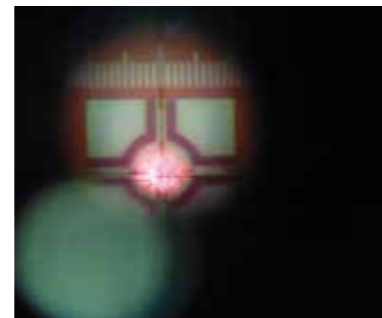

RS96 – Stake out work on the floor slab

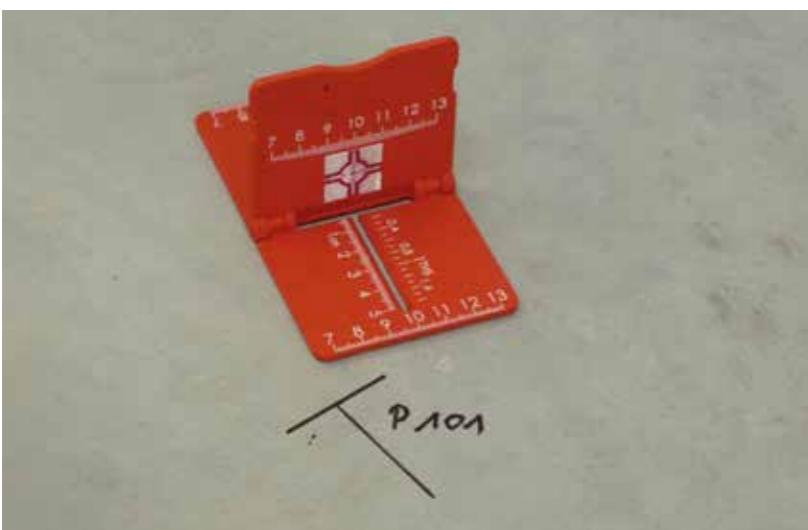

Stake Out Aids RS95, RS96 with Reflective Target and RS97 with Non-reflective Target



Stake out aids RS95, RS96 and RS97 were developed specifically for setting out work on the batter board and on a floor slab. Exact measurement of the survey point on the floor slab often causes major problems particularly in the "final phase" with the last 5-10 cm. The work is very time-consuming due to the continual side to side, backwards and forwards with the prism pole and the prism pole always has to be exactly plumb. The Stake Out Aid RS95 or the folding Stake Out Aid RS96 or RS97 is placed on the floor and, thanks to the inscribed measurement scales, the assistant can transfer the surveyor's directions quickly and precisely.

Advantages of the stake out aids:

- They make surveying the axes on the batter board easier
- Dimensions on the floor slab can be surveyed quickly and exactly
- The surveyor's information about direction can be transferred quick and precisely
- There is no prism pole to be set plumb
- Orientation scales for left and right: the number 10 corresponds to the axis
- Orientation scales for backwards and forwards
- Foldable: fits in any shirt pocket and in any instrument case! (RS96/RS97)
- With little practice, the time saving becomes enormous

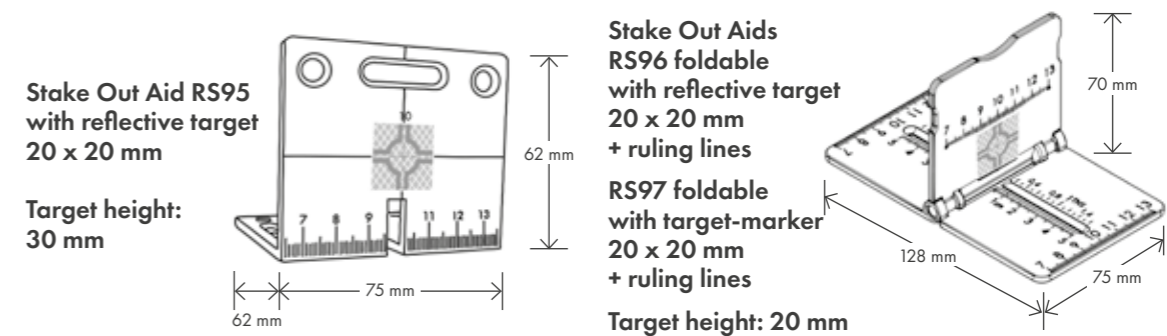



Staking out with the Stake Out Aid for Robotic Total Stations RS150M*



Move the stake out aid on the base plate until the target position is reached – visible on the green circle.



Slide the prism to one side and mark the target position with a pencil.

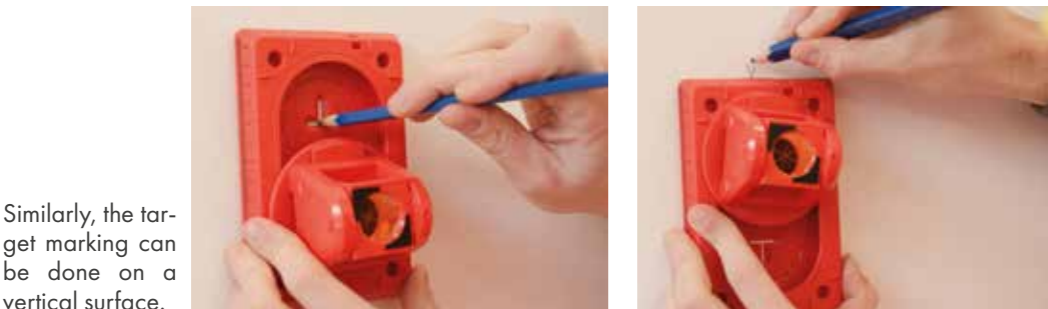

Similarly, the target marking can be done on a vertical surface.

Fast transfer of heights with set height offset of 50 mm in the total station.

Stake Out Aid for Robotic Total Stations RS150M*



NEW
SUITCASE SET
KS1-390M+
Page 76

An innovative new solution for staking out measuring points quickly and accurately on horizontal or vertical surfaces using robotic total stations.

After reaching the point to be measured, the particular measuring point is revealed directly below the prism by simply sliding the prism from position A to position B and vice versa, and can be marked directly via a cavity in the base plate.

Advantages:

- Precise and fast setting out
- Direct marking of the point to be measured on horizontal and vertical surfaces
- With a 50 mm height offset set in the total station, heights can be marked directly at the top and bottom edge without moving the prism
- Prism always remains aligned to the instrument
- Paying attention to a horizontal position by means of a spirit level is not necessary, as the tilting axis height is only 50 mm
- Fast transfer of heights with set height offset of 50 mm in the total station.

On YouTube/Rothbucher Systeme we show how easily and quickly points can be staked out.

Stake Out Aid RS150M*

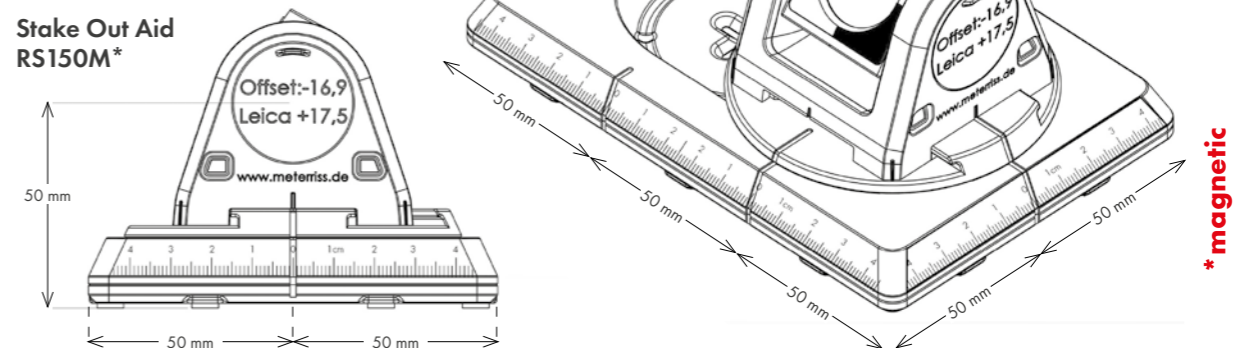



Mini Prisms RSMP10, RSMP12 and RSMP15



RSMP10 with 12.7 mm and RSMP12 with 17.5 mm mini prism

With the mini prisms RSMP10 and RSMP12, surveyors can measure in gaps, holes and corners easily and quickly. Fixed dimensions (see product drawings) give the surveyor the exact path from the point of measurement to the base of the housing or the tip of the spike. In forensics, the use of prisms include the exact surveying of bullet holes. PLEASE NOTE: For precise measurements, the prism must be exactly aligned with the surveying instrument!

When using the mini prisms for settlement measurements, the spikes can be removed and thus be inserted or glued into the smallest cracks or holes. On façades, historical buildings, supports and lots of other objects, monitoring is possible with measuring points that are barely identifiable by the general public. At concrete or masonry objects, small holes can be drilled to countersink the prisms flush with the surface.

Angle Plate RSMP15 with 12.7 mm mini prism

For quick mounting, RSMP15 with 12.7 mm mini prism is easily glued, even to difficult surfaces such as marble façades, historic buildings, steel work, rail tracks, gas and oil pipelines.

When using robotic total stations:

- Permanent settlement monitoring can be carried out during the building work
- Settlement measurements on railway tracks are possible while under the load of rail traffic
- Bridges and other structures can be monitored even more quickly and precisely

The prisms can be used at an angle of up to 25°.

In the event of problems with the angle or when measuring from greater distances, we recommend our tilting mini prisms – see following pages.



RSMP15 Hearst Castle USA



RSMP15 for surveying with robotic total station while under load



RSMP10 can be placed in the smallest gaps.



RSMP12 – almost invisible to passers-by

RSMP10 mini prism Ø 12.7

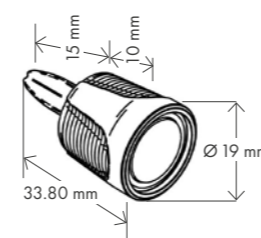

RSMP12 mini prism Ø 17.5

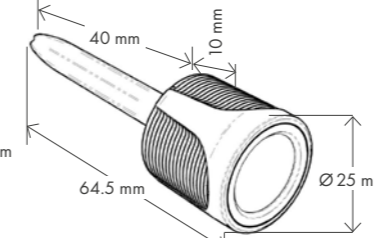

RSMP15 mini prism Ø 12.7

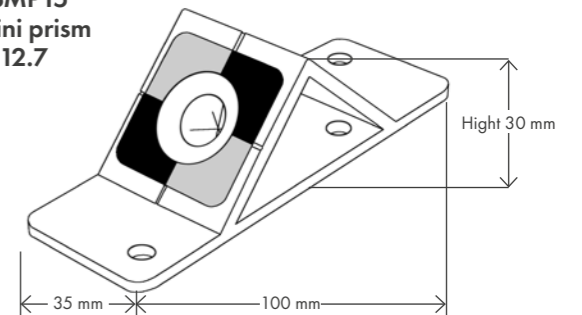

RSMP10 with Ø 12.7 mm mini prism: offset -5.6 (minus 5.6) [Leica +28.8]
 RSMP12 with Ø 17.5 mm mini prism: offset -5.4 (minus 5.4) [Leica +29.0]
 RSMP15 with Ø 12.7 mm mini prism: offset -5.6 (minus 5.6) [Leica +28.8]



See page 64
**FIXED POINT
 SYSTEM**
RSFP-X80

Mini Prisms with Tilt Function RSMP380 and RSMP380M*

Proven Precision:
 „White Paper“
 on these products
 available!



Mini Prisms RSMP380 and RSMP380M* with silver or copper coated Ø 25.4 mm prism

When using these mini prisms, the measuring points can always be exactly aligned with the measuring instrument and turned through 180°. This enables the same survey point to be used from different directions. Bridges, façades and lots of other objects can thus be monitored more quickly and precisely. The integral plug-in system enables prisms to be combined with one another, permitting surveying from different directions without needing to rotate the prism.

Using the mounting plate RSFP-X80, you can easily fix the prisms, even on difficult surfaces, by means of our RSMK-FIX mounting adhesive. After completion of the survey, they can be removed quickly and easily and, if need be, re-affixed. The mounting plate RSFP-X80 is designed in a way so that the prisms can be clipped in – exactly centered – in two directions. The same survey point can thus be used from almost all directions. If the mounting plate RSFP-X80 is used in high-vibration environments (e.g. if mounted on railway tracks), the prisms can be secured to the mounting plate with small screws. If necessary, fastening them with screws is also possible.

With mini prism RSMP380, ranges of 500 m to 700 m can be achieved in ATR mode. The ranges depend on the survey instrument and are influenced by weather and ambient conditions.

Especially for monitoring of tracks and steel constructions we offer a magnetic version of our mini prism, article **RSMP380M***:

- Fastest fixing ever – even on wet surfaces
 - No need to clean or dry the surface
 - Prism or magnet are available separately
- The product has been tested under the most difficult weather conditions!

Caution: At temperatures above 80 degrees Celsius (176° F), the magnets may lose their adhesive force. If such high temperatures are possible on the surface in your area of application, we recommend adding a little glue or generally gluing the prisms.

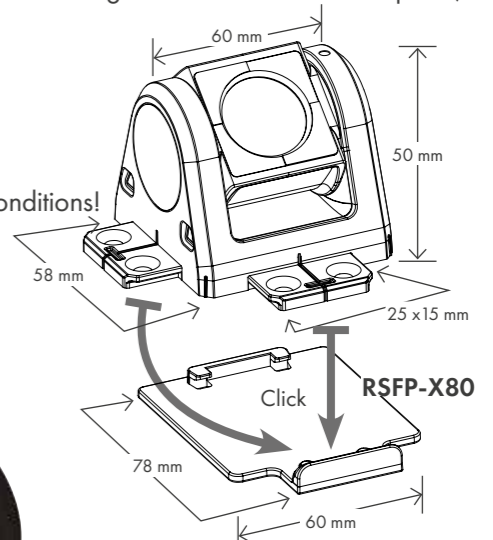

RSMP380 with Ø 25.4 mm mini prism:
 offset -16.9 (minus 16.9) [Leica +17.5]
 Tilting axis height RSMP380: 30 mm

* magnetic

Magnet (including connecting screw) and prism can be ordered separately



Application film on YouTube



Simple and fast fitting on any substrate



RSMP380 with mounting plate RSFP-X80g



Monitoring of HMS Victory in the Historic Dockyard, Portsmouth

Mini Prisms with Swivel and Tilt Function RSMP390 and RSMP390M*

Proven Precision:
„White Paper“
on these products
available!



Mini Prism RSMP390 and RSMP390M* with silver or copper coated, Ø 25.4 mm prism

An extensive range of accessories are available for mounting prisms on different surfaces. Solutions for all kinds of mounting requirements on concrete, glass, rocks, historic buildings, oil and gas pipelines, metal and many other difficult surfaces are part of the standard repertoire – see pages 65 to 75.

When using total stations or robotic total stations:

- The prism can always precisely be aligned with the survey instrument
- The prism can be rotated through 360°, enabling the same survey point to be used from almost any direction
- Bridges, façades and many other objects can thus be monitored more quickly and precisely
- Permanent settlement monitoring can be carried out during the building work

A product from the series “A reference point for all instruments”

With mini prism RSMP390(M*), ranges of 500 m to 700 m can be achieved in ATR mode. The ranges depend on the survey instrument and are influenced by weather and ambient conditions.

When sighting survey points that are already known, ranges of up to 1000 m can be achieved with robotic total stations!

For measurements in manual mode, depending on the focus, ranges of approx. 200 m can be obtained.

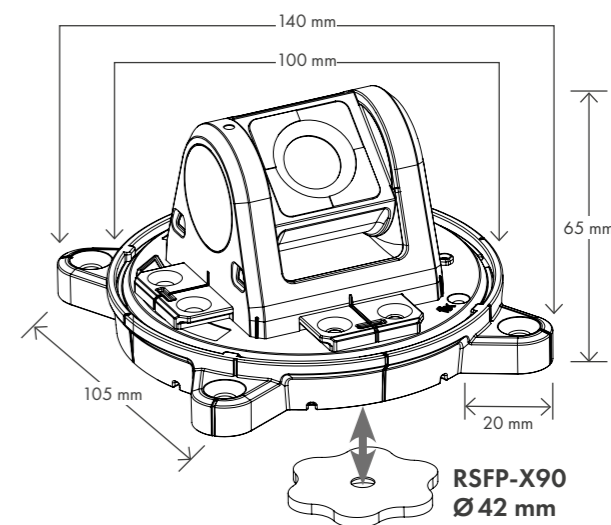

RSMP390(M*) with Ø 25.4 mm mini prism:
offset -16.9 (minus 16.9) [Leica +17.5]

Tilting axis height for RSMP390(M*): 45 mm

See pages 65/66
**FIXED POINT
SYSTEM**
RSFP-X90

NEW
SUITCASE SET
KS1-390M+
Page 76

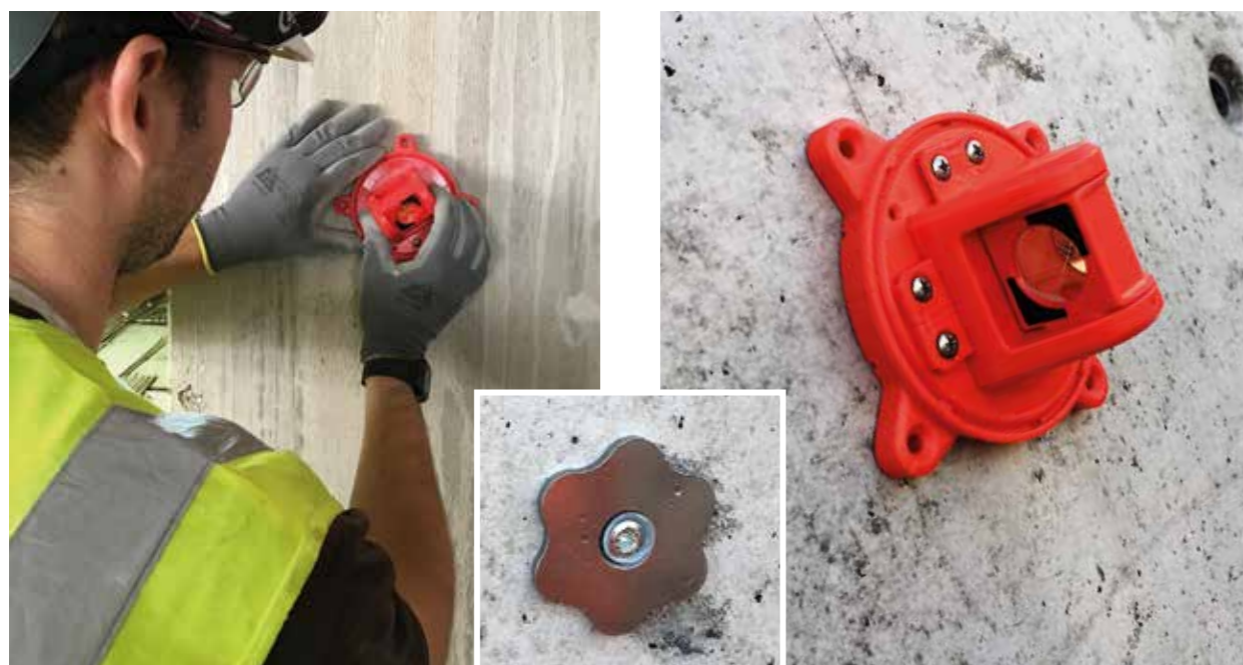

RSFP-X90 (small picture, centre) as restore point for mini prism RSMP290rM or RSMP390rM



See pages 64-67
FIXED POINT SYSTEM
RSFP-X80+X90

220° Mini Prisms
RSMP480, RSMP480M* and RSMP490M*



A prism that sets standards

- Enables reference points to be located from virtually any direction
- Thanks to the RS range of accessories, quick and easy mounting on almost all surfaces is guaranteed – see accessories pages 63 to 75
- Also available as version RSMP480M for track monitoring

Experience has shown that the best measurement results are achieved when the prisms are aimed manually. Accuracies in the range of ± 1 mm are possible.

The combination of easy mounting on almost all surfaces with our accessories and the possibility of being able to use the measuring point from all sides makes these prisms something special.

A product from the series "A reference point for all instruments"



RSMP490M

Easy fixing with maximum flexibility leave nothing to be desired. One prism for many applications!



RSMP495M



RSMP480M

RSMP490M* with 220° Prism:
Offset: 0 (zero) [Leica +34.4]
Tilting axis height: 45 mm

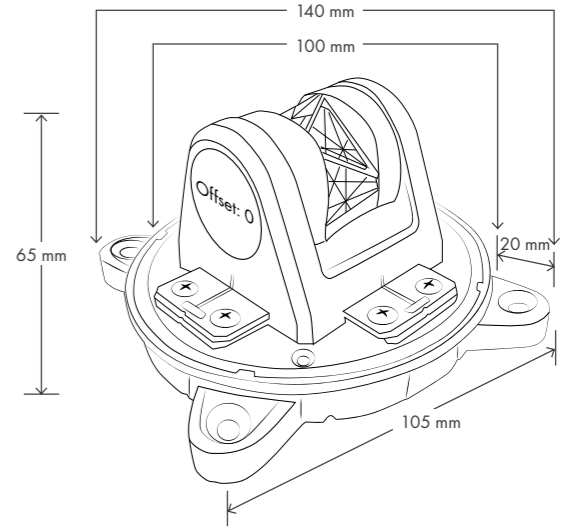

RSMP480 with 220° Prism:
Offset: 0 (zero) [Leica +34.4]
Tilting axis height: 30 mm

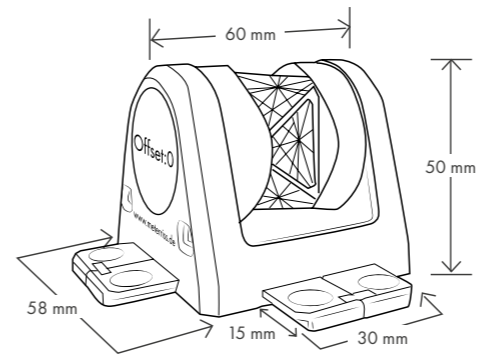

* magnetic

Accessories for these products on pages 63 to 75

Laser Scanner Targets RSL301* and RSL322

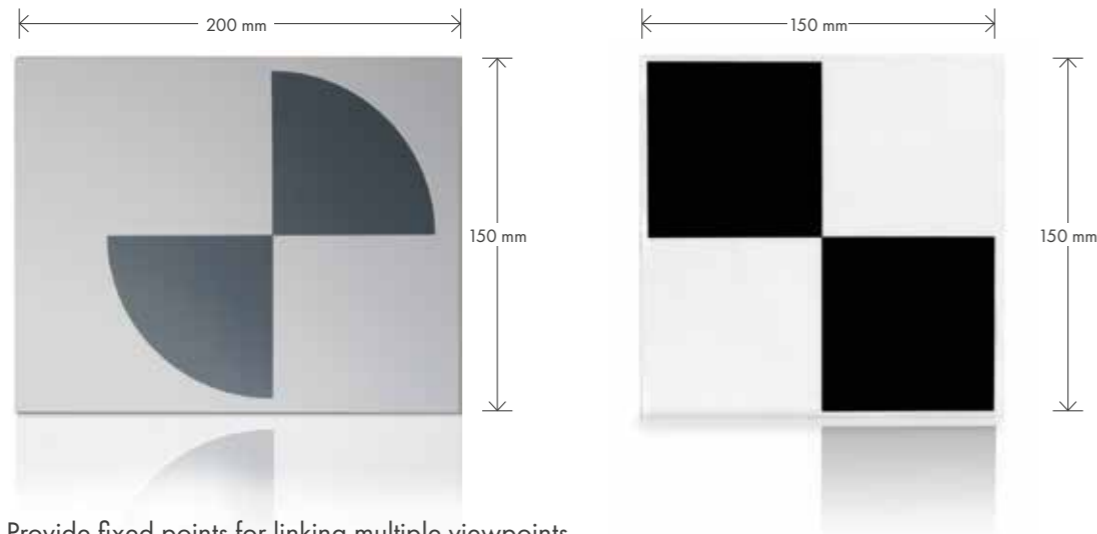

- Provide fixed points for linking multiple viewpoints
- For the assignment of spatial reference information to a geospatial data set
- Quickly and easily mounted
- Suitable for inside and outside use

RSL301*

Ideally suited for use with scanners from Leica, GeoMax, Faro and ZF. These targets are self-adhesive and can be used multiple times on smooth surfaces. For outside, we recommend using an extra adhesive. A labelling field facilitates clear assignment of the measuring points.

RSL322

The targets are ideal for scanning and photogrammetric survey for linking points from inside to outside and vice versa using scanners but also scanners and drones. When using scanners, we recommend using the targets on the outer glass surface. The targets should be used on plastic surfaces only for a short time.



* self-adhesive



Laser Scanner Target foldable RSL496



- Ideally suited for use with scanners from Leica, GeoMax, Faro, ZF and Trimble as well as the scan function of the Leica MS50 and for the RIEGL VZ 400 from a distance of 50 m
 - Fixed points for connecting several positions
 - Assignment of spatial reference information to a geospatial data set
 - Can be used from two sides since it is printed on both sides (offset +2 mm)
 - Suitable for inside- and outside use
 - **This target can be folded flat for storage when not in use – No need to carry bulky tripods**
- One sales unit of 10 pieces with a weight of 0.9 kg and with the dimensions of 220 x 130 x 95 mm fits in any rucksack.



RSL496 offset +2 mm with dual side use

Marking through a slot in the base plate makes repeated measurements possible.

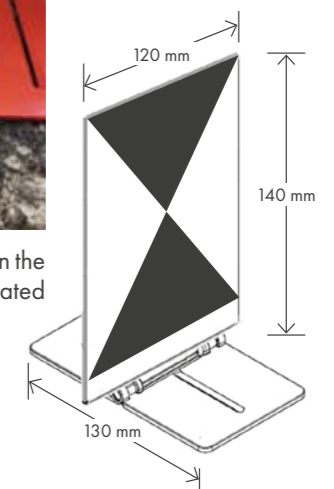

Laser Scanner Target RSL-X80

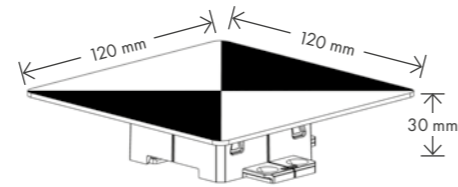

- Ideally suited for use with scanners from Leica, GeoMax, Faro, ZF and Trimble
- Also perfectly suited for Lidar and SLAM, e.g. instruments from NavVis
- Provides fixed points for linking multiple viewpoints
- Assignment of spatial reference information to a geospatial dataset
- Higher accuracy since the fixed point can be surveyed with total station in advance (e.g. with the mini prism RSMP380) – see page 64
- If need be, all markers can also be permanently glued or fixed



For repeat surveys, only the reference point (RSFP-X80) remains on the object (e.g. on a façade).



With the adapter RSA-X80g-1, the laser scanner target can exactly be fitted above the measuring point of the RS mini prism RSMP380. The height offset is 60 mm.



Laser Scanner Target RSL-X90M*

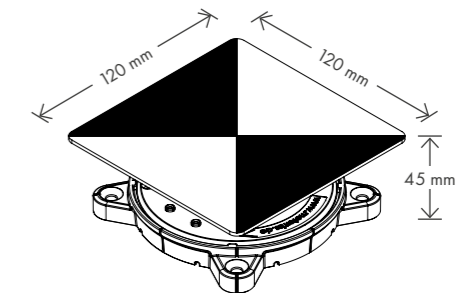
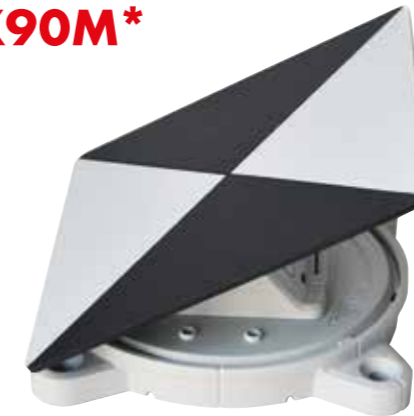

- Ideally suited for use with scanners from Leica, GeoMax, Faro, ZF an Trimble
- Also perfectly suited for Lidar and SLAM, e.g. instruments from NavVis
- Provides fixed points for linking multiple viewpoints
- Assignment of spatial reference information to a geospatial data set
- Higher accuracy since in advance, the fixed point can be surveyed with total station (e.g. with the mini prism RSMP390M*) – see pages 65/66
- If need be, all markers can also be permanently glued or fixed

A product from the series "A reference point for all instruments"

For repeat measurements, only a small, barely visible, stainless steel survey mark (RSFP-X90) is left on the object as a reference point (e.g. on bridges or façades).

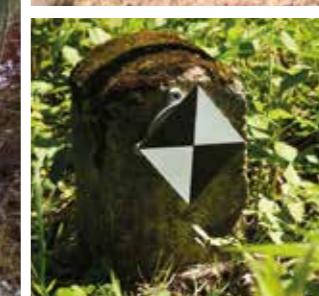
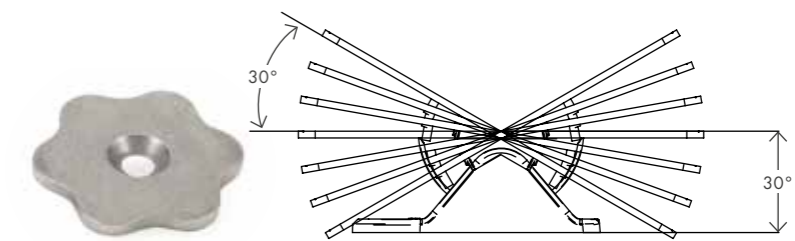

* magnetic

DIBOND Mobile Mapping-, Scanner- and Drone Targets

RSL-X94M* und RSL-X95M*



RSL-X94M* tilting axis height 45 mm RSL-X95M* tilting axis height 100 mm

- When using these targets with a scanner or ground control, they are recognised by the instruments from a greater distance or height.
- It is also possible to measure the reference points precisely in advance with total stations, whereby accuracies of ± 1 mm can be achieved.
- In tunnels, the reference points RSFP-X90 to RSFP-X99 are first measured with the mini prism RSMP390M* or RSMP395M*. The reference points are then interchangeable with the targets RSL-X94M* or RSL-X95M*. Thus, these targets provide perfect and precise orientation for mobile mapping.
- For even more precise measurements using ground controls, the targets can be placed on a tripod directly above the centre of a prism.

A product from the series "A reference point for all instruments"



* magnetic

DIBOND Laser Scanner and Drone Sign RSL402



Laser scanner sign, 400 x 400 mm, for long range scanning.

The rear face, printed in black & white, can be used as a ground marker for drones.

- When using mobile mapping systems, the plates can even be recognized at speeds of up to 80 km/h (50 miles/h)
- Because of their size and shape, the plates can also be used for orienteering in systems for autonomous driving
- Can be secured to the ground with tent pegs





Laser scanner target RSL422M in a tunnel



RSL422M on reference point RSFP-X99-12



RSL420M on suction cup RSSV-X90



RSL422M on floor stand RSFP-X98

Laser Scanner Targets with Swivel and Tilt Function RSL420M* and RSL422M*

Siehe pages 65/66
FIXED POINT SYSTEM
RSFP-X90



NEW
SUITCASE SET
KS2-420M/-2
KS2-422M/-2
 Page 77

First-class workmanship, a high level of precision and a special magnetic base make these targets something special:

- Ball bearing joints allow the laser scanner target to be aligned smoothly in any direction while always remaining precisely on axis and in position.
- The target can be used as a scanner or drone target
- Available in two versions:
 - A) Article RSL420M* – printed on one side with offset 0 and
 - B) Article RSL422M* – printed on both sides with offset +1.5 mm
- Fixed points for linking several viewpoints
- Assignment of spatial reference information to a geodata set
- Suitable for inside and outside use

A strong magnetic base gives the products that extra capability:

- The cavity on the magnetic base for use in conjunction with the fixed point system RSFP-X90 to RSFP-X99 makes the targets universally applicable
- We show the resulting countless number of possibilities on pages 65 to 75

A product from the series "A reference point for all instruments"

Diameter:
 Ø 145 mm
 Tilting axis height:
 100 mm
 Weight: 500 g

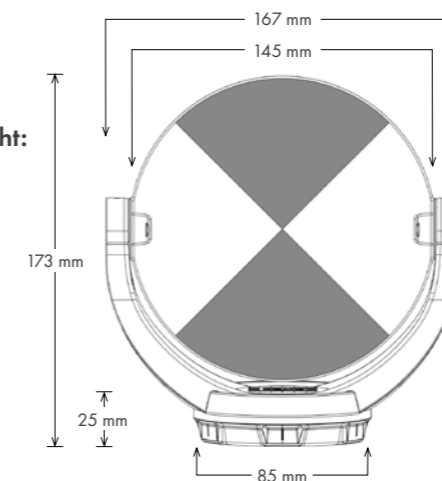

RSL420M*/ RSL422M* on suction cup RSSV-X90
 Enables the laser scanner target to be used on any smooth surface such as glass or smooth furniture fronts with no drilling or gluing!

* magnetic

Laser Scanner Spheres

RSLB10M*

RSLB10SV



Laser Scanner Sphere magnetic RSLB10M* with magnetic base

Laser Scanner Sphere with suction cup RSLB10SV

- Scanning sphere made from shockproof plastic featuring special matt textured finish for optimum reflectivity
- Washable and dishwasher-safe surface
- Fixed points for linking several viewpoints
- Can be used from all sides
- Suitable for inside and outside use

A strong magnetic base gives the products that extra capability:

- The cavity on the magnetic base for use in conjunction with the fixed point system RSFP-X90 to RSFP-X99 makes the targets universally applicable
- We show the resulting countless number of possibilities on pages 65 to 75
 - A) Can be used on any standard tripod
 - B) Exact placement over an RS mini prism
- Due to the product weight, we recommend as a reference point the RSFP-X99 series with a higher magnetic adhesion

A product from the series "A reference point for all instruments"

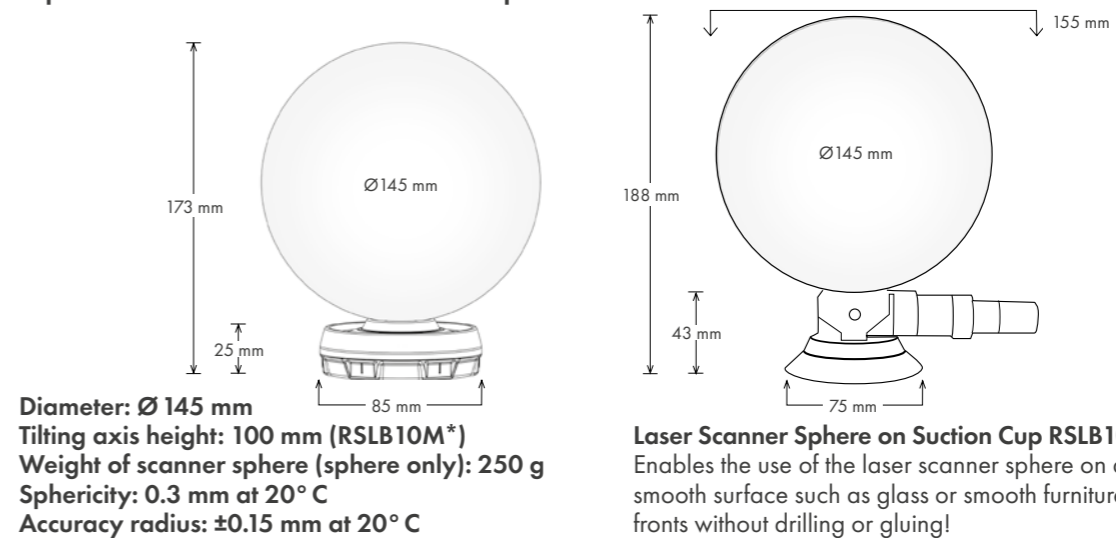

* magnetic





SLAM Target RSL430 on floor stand RSFP-X98



SLAM Target RSL452M* on suction cup RSSV-X90. Can also be used for RIEGL scanners.

Laser Scanner and SLAM Targets RSL430 and RSL452M*

See pages 65/66
FIXED POINT
SYSTEM
RSFP-X90

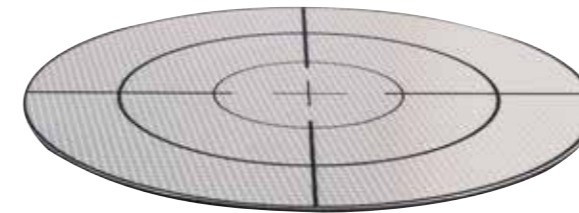

RSL430

optionally supplied with RSA-490M* adapter

- The RSL430 laser scanner and SLAM target is automatically detected by shape and reflection when using appropriate software.
- Is frequently used as a ground control target
- For vertical target use e.g. at the roadside, the RSA-490M* adapter is available. Its magnetic base also makes it possible to use on a tripod. The RSFP-X90-1 adapter is required as a connecting piece.

Soon available:
a rotatable and tiltable version
with magnetic base



RSL452M* rotatable and tiltable with magnetic base

- Ball bearing joints allow the laser scanner target to be aligned smoothly in any direction while always remaining precisely on axis and in position.
- The target can be used as a scanner or drone target
- Fixed points for linking several viewpoints
- Assignment of spatial reference information to a geodata set
- Suitable for inside and outside use

A strong magnetic base gives the products that extra capability:

- The cavity on the magnetic base for use in conjunction with the fixed point system RSFP-X90 to RSFP-X99 makes the targets universally applicable
- We show the resulting countless number of possibilities on pages 65 to 75
- One example of the many possibilities: When used inside, our socket adapters and suction cups allow you to create permanent reference points without leaving any marks!

A product from the series "A reference point for all instruments"

NEW
SUITCASE SET
KS2-452M/-2
Seite 77

* magnetic

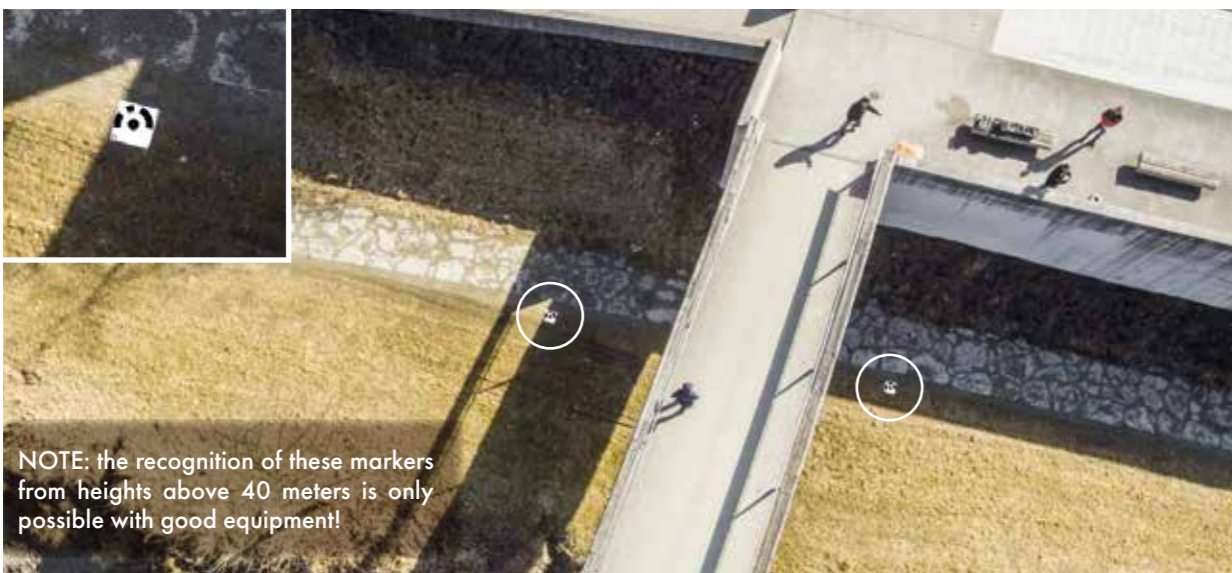
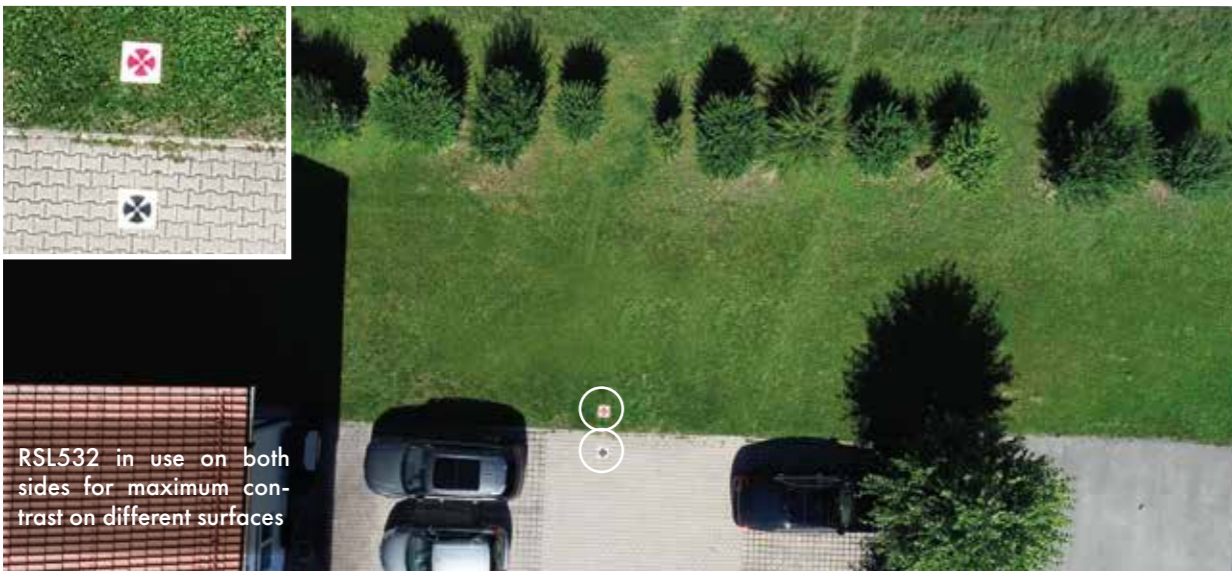

NOTE: the recognition of these markers from heights above 40 meters is only possible with good equipment!

Ground Control Targets for Drones

- with cross RSL510 and RSL512

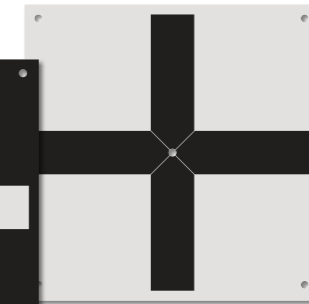
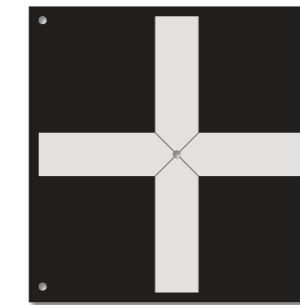
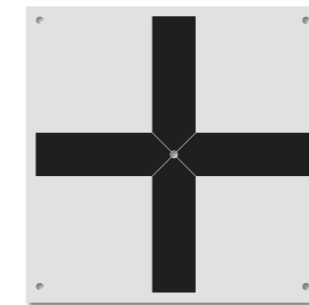

RSL512 printed on both sides for maximum contrast on different surfaces

- with circle RSL520 and RSL532

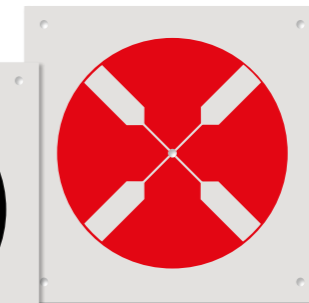
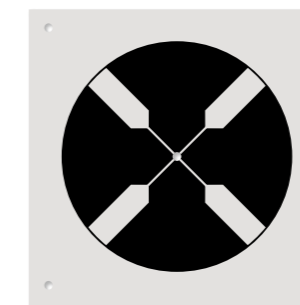
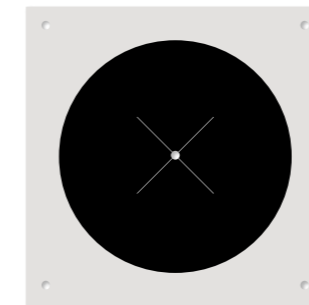

RSL532 printed on both sides for maximum contrast on different surfaces

- with numbering RSL570-10, RSL570-20 and RSL570-30



Numbering 1 - 10

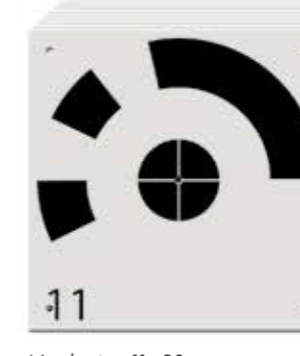

Numbering 11 - 20

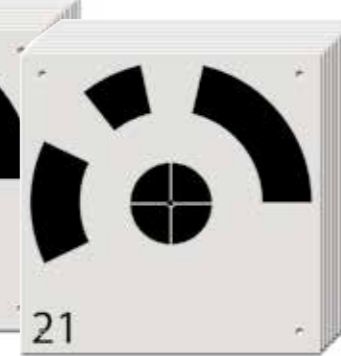

Numbering 21 - 30

- Large, waterproofed target markers
- Size 350 x 350 mm
- UV resistant
- Fixed points for use with drones
- A central hole permits exact calibration by GPS
- Can be secured to the ground with tent pegs
- Can be used lots of times

- Ideal for use up to a height of approx. 100 meters, for heights above 100 meters, we recommend the hinged ground markers (see next page)
- **Marker visibility is device and weather-dependent**
- Automatic number recognition with appropriate software such as: Agisoft (RSL570-10, RSL570-20, RSL570-30)



Drone target RSL512XL



Drone target RSL532XL

Ground Control Targets for Drones, unfoldable

- RSL512XL, unfoldable with cross

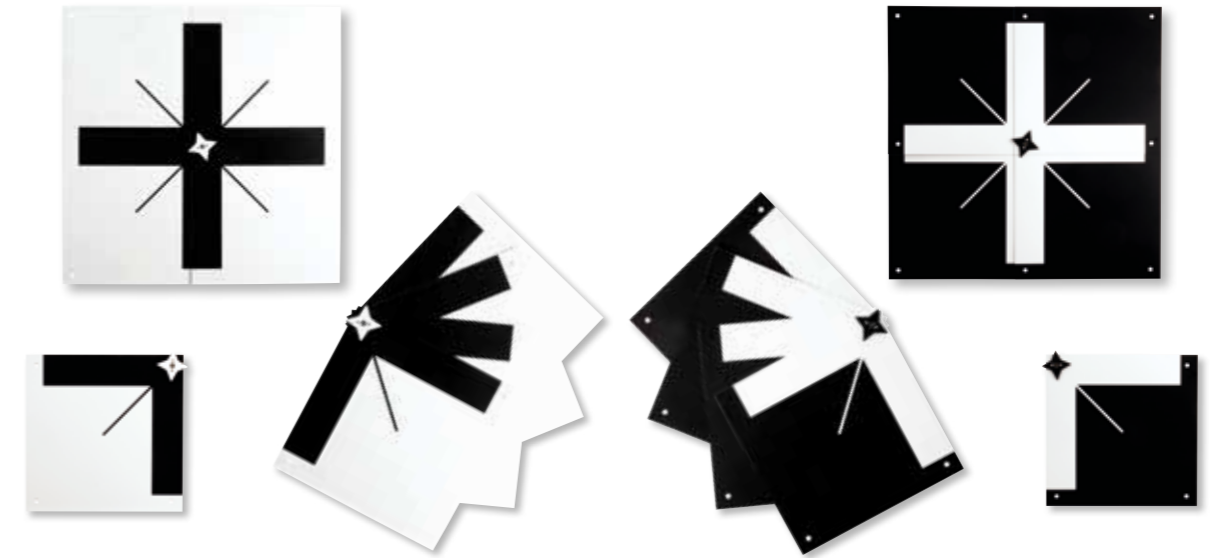

- RSL532XL, unfoldable with circle

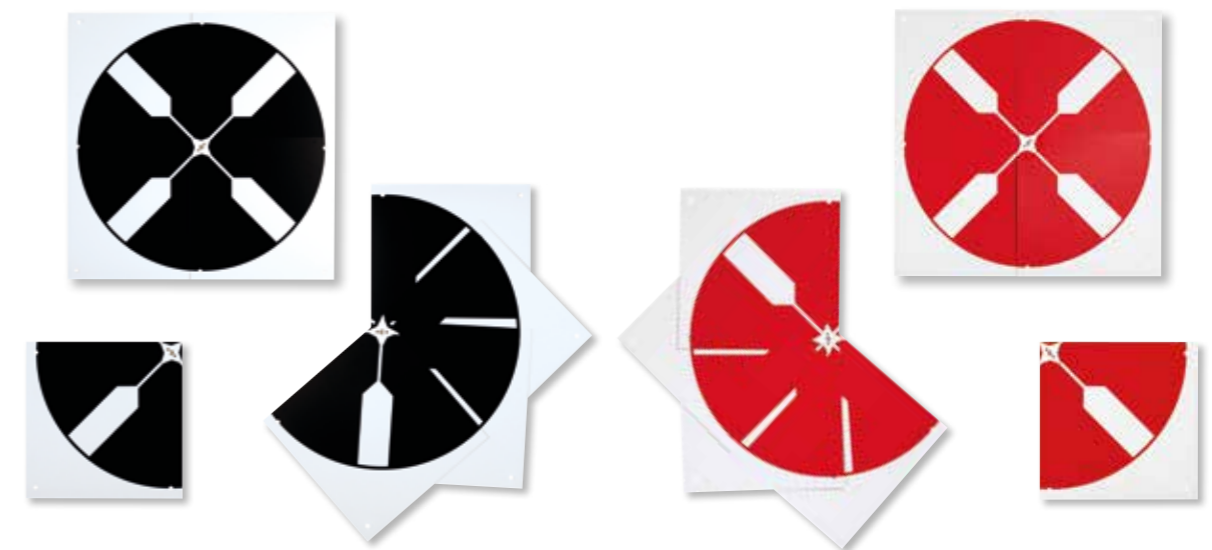

- Large, waterproofed target markers
- UV resistant
- Size 350 x 350 mm closed, 650 x 650 mm opened
- Fixed points for use with drones
- A central hole permits exact calibration by GPS

- Can be secured to the ground with tent pegs
- Can be used lots of times
- Ideal for heights above 100 meters
- **Marker visibility is device and weather-dependent**
- Printed on both sides, depending on the background, the lighter or darker side can be used

Drone Targets RSL580-10 and RSL580-20



Still higher accuracy when using scanners and drones

Combined with the fixed point RSFP-X80, the reference points can first be surveyed exactly with our mini prisms (e.g. RSMP380). The drone markers RSL580 can then be clipped into the same fixed point for the use of drones (see page 64). With adequate quality of the cameras or surveying instruments, accuracies of ± 1 mm can be achieved.

In combination with the adapter RSA-X80g-1, the RSL580 drone markers can be placed exactly above the surveying point of the mini prism. With the adapter RSA-5/8-1, this combination can be mounted on any current tribrach or tripod with 5/8" unc thread.

See illustrations below.

With high-quality cameras, accuracies of ± 1 mm have already been achieved from an altitude of 35 meters!

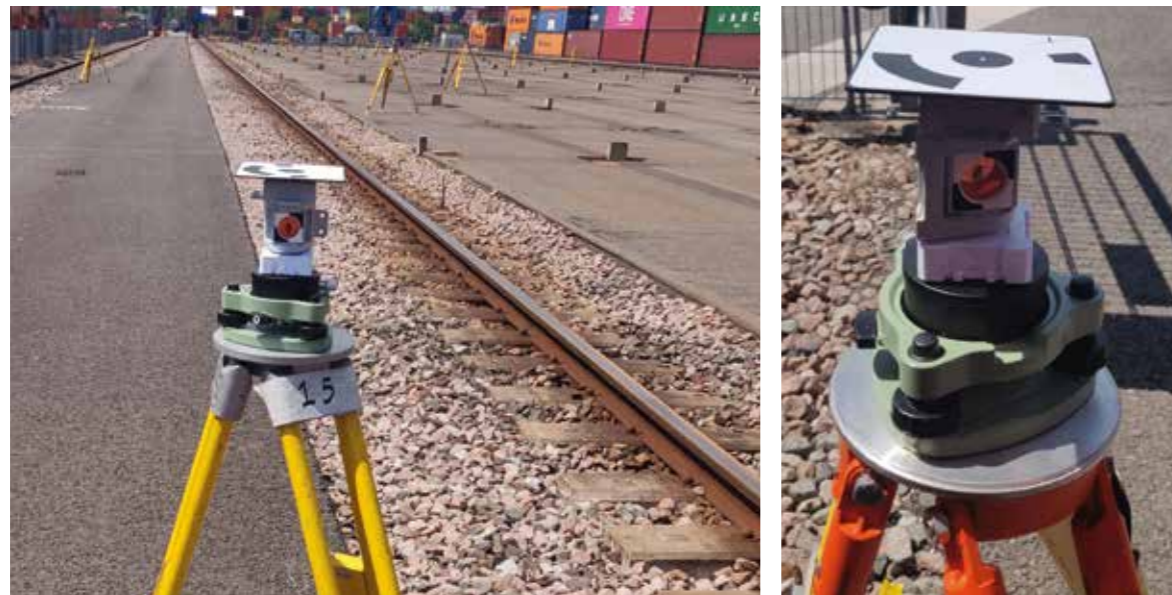

Drone Targets RSL590M-10* and RSL590M-20*

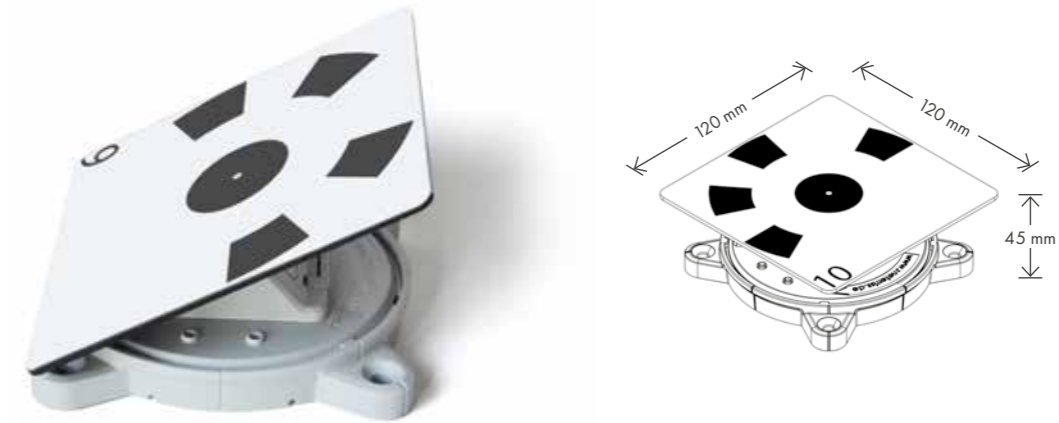

Combined with the fixed point system RSFP-X90, the reference points can first be exactly surveyed with our mini prisms (e.g. RSMP390M*).

The drone markers RSL590M* can then be placed on the reference points for the use of drones (see pages 65/66).

Very exact assignment of spatial reference information to a geospatial data set is thereby achieved. Accuracy ± 1 mm.

For repeat measurements, only a small, barely visible, stainless steel survey mark (RSFP-X90) is left on the object as a reference point (e.g. on bridges or buildings).

A product from the series "A reference point for all instruments"



* magnetic



4/4 Boundary Markers RSKM10 to RSKM40

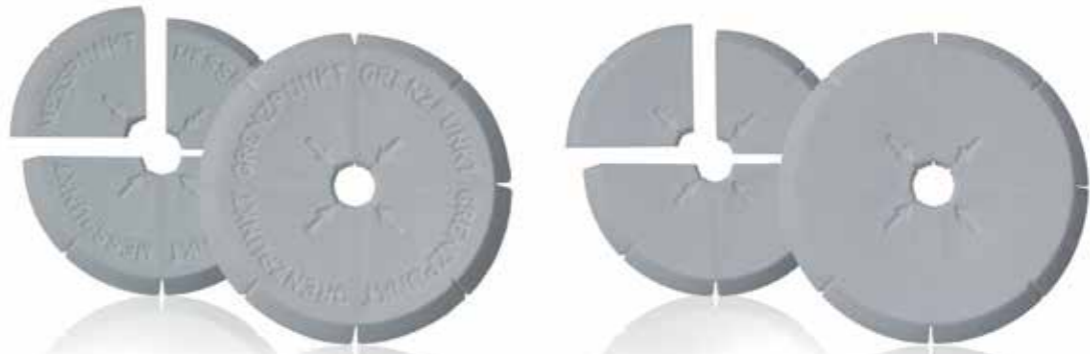

The targets with an adhesive backing are used as a boundary or measuring point on hard ground. To be able to document the boundary or measuring point more precisely on corners or edges, the markers have an indentation on the back to be able to divide them easily into up to 4 pieces. Therefore, accurate documentation is ensured at inner corners, along walls and at outer corners.

Our RSMK-FIX glue is ideal for affixing markers.

The following products are available:

- RSKM10: 4/4 Boundary Markers without inscription
- RSKM20: 4/4 Boundary Markers with inscription "GRENZPUNKT"
- RSKM30: 4/4 Boundary Markers with inscription "MESSPUNKT"
- RSKM40: 4/4 Boundary Markers with inscription "SURVEY MARK"

RSKM10 to RSKM40

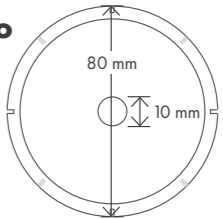

Fixed Point RSFP1 and Protection Cap RSFP1-A



When used as a fixed point on the ground, this point can be surveyed with a prism so it can be checked quickly and easily if necessary, for example if it is suspected that the fixed point has been moved due to outside interference.

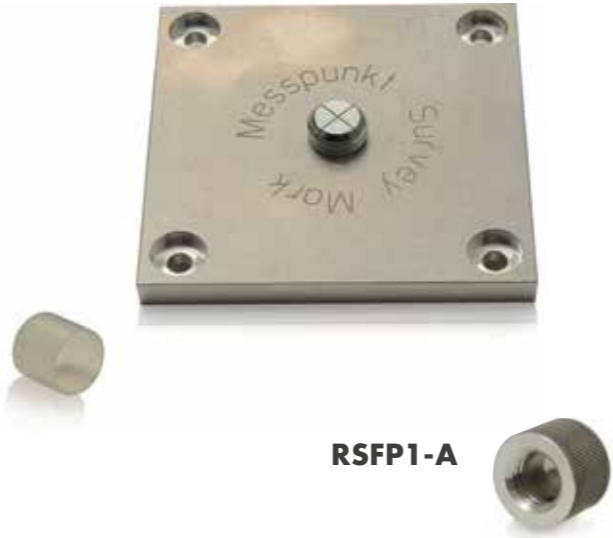

The aluminum plate RSFP1 is fitted with a 5/8" unc stainless steel male thread for screwing on a prism or a measuring instrument. If the plate is used as a fixed point on the ground, the surveyor can position his instrument on his tripod precisely above the cross.

The fixed point RSFP1 is supplied with a plastic protection cap for the 5/8" unc thread. An aluminum protection cap RSFP1-A with 5/8" female thread is also available.

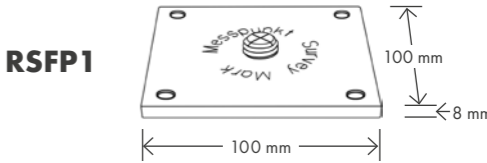

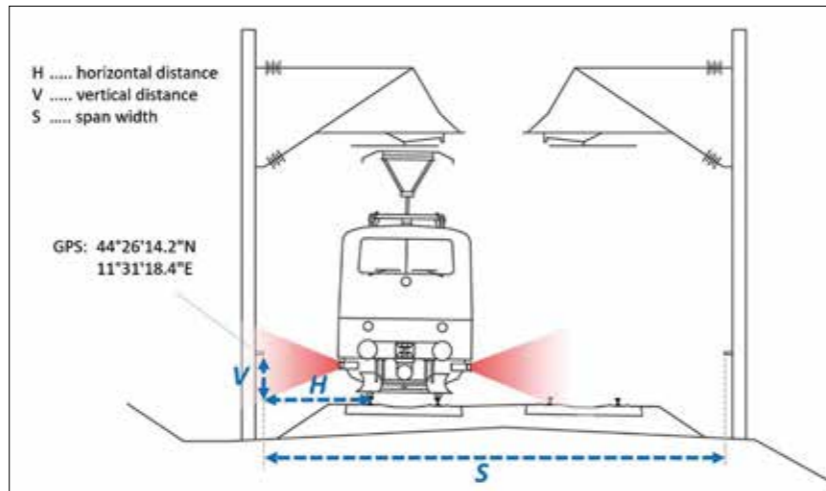

The measurement values of the RPM system

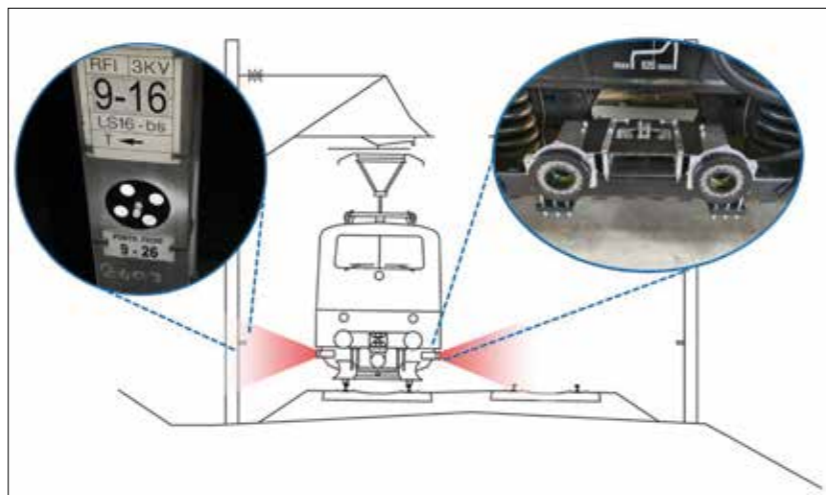

The measuring target mounted on a side post (left) and the RPM stereo-camera system (right)



The RPM system installed on the 08-275 Unimat Combi (RFI Italia) tamping machine

Track Machine Targets

TMT10

TMT20, TMT25

TMT30



Special targets to surveying the absolute track geometry with the RPM stereo camera system

The Reference Point Measurement (RPM) system is a high speed measuring system for track geometry. The resulting track geometry is the fundamental data basis for the tamping machine to maintain perfect track position.

Reference points with known coordinates are used to determine the absolute position of the rail track at speeds up to 100 km/h. A stereo-camera measures the distance between the wheel flange point of the rail and the reference point with a ± 2 mm accuracy. Combined with the relative track geometry of the inertial measurement system the result is a high precision 3D trajectory in geo-coordinates.

The RPM system uses two stereo-cameras mounted on each side of the vehicle for measuring the distance between the wheel flange point and the reference point. Dedicated flashlights ensure reliable operation at day and night time. The dedicated measuring target is installed on either existing reference points (metallic bolts) or a new reference geometry is established with an initial measuring run.

Accessory for TMT10 round marker



Starlock disc (11 mm / 12 mm)



Assembly aid for starlock disc

Laser Target, foldable RSLT10

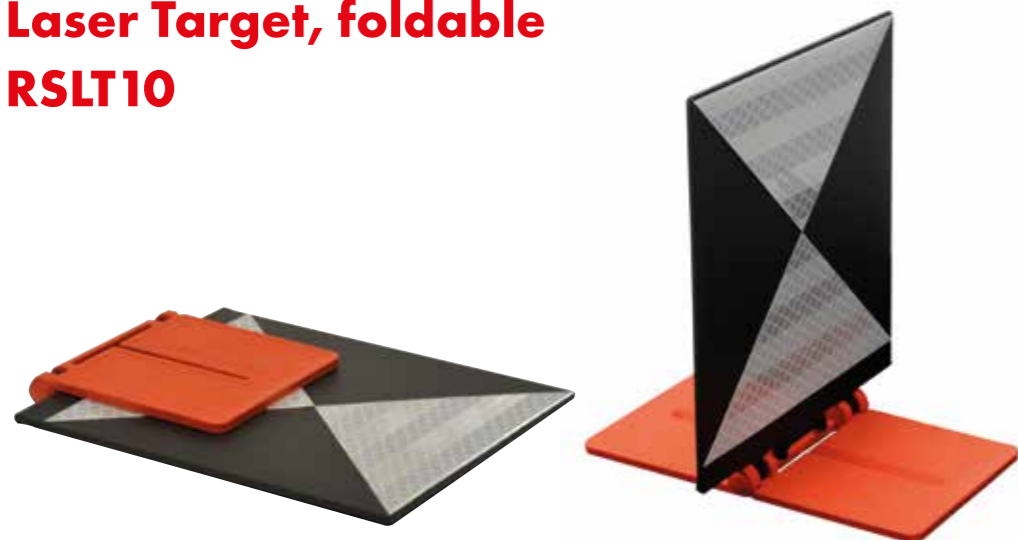

The laser target RSLT10 was developed for the fast and exact alignment of a line laser on axis. The laser target can be folded down and can therefore be stored in the laser box or stowed away in another space saving place.

Place the laser target on the axis on which you want to align the laser. Turn the laser with active axis line in the area of the laser target to left and right until you see the laser line on the laser target and align the laser on the center of the target.

Please note: For alignment, your head must be at the same height as and next to or behind the laser. Only then can the reflection of the laser line from the target be clearly seen and, even in bright sunlight, be used at a range of up to 30 m.

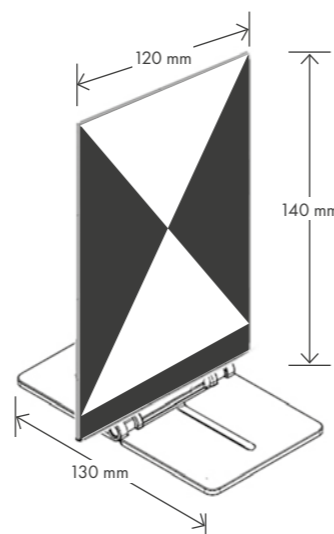

Products from our system

One fixed point for all instruments

Fixed Point RSFP-X80

Fixed Point for RS183, RSMP380, RSMP480, RSL-X80 and RSL580

The fixed point can be glued to all common surfaces. For quick and easy fixing we recommend our construction glue RSMK-FIX.

This product is especially popular for monitoring on tracks. When all the work has been completed, the prism can be easily and quickly removed from the plate. All that remains is the low-cost fixed point RSFP-X80.



RSMS1033 magnet pot for X80 targets and prisms

These products are used in particular for surveying in steel construction, in ships or for calibrating excavator controls.

The magnet is placed over the survey point by means of a cavity in the centre. Then the target or prism is placed on the magnet with the "pot" and aligned with the measuring instrument – and you're done!

Conversely, it is also very easy to create a fixed point.

Replacement magnets (RSM1030) are available as accessories.



Suction Cup RSSV-X80

Version Ø 75 mm for RS183, RSMP380, RSMP480, RSL-X80 and RSL580

For all glass and smooth surfaces, inside and outside. Its pump function allows the suction cup to be firmly attached to the surface.

Simple and quick installation – with no gluing or drilling required – is so guaranteed.



ONE FIXED POINT FOR ALL INSTRUMENTS
RSFP-X80

Fixed Point System RSFP-X80, Suction Cup RSSV-X80 and Magnet Pot



For all instruments the same reference point!

- Depending on the instruments, accuracies of ± 1 mm are possible
- With the mounting plate RSFP-X80, various products can be fixed well and quickly. At the end of the survey, only the low-cost mounting plate (resumption point) remains on the object as a reference point
- On building sites, the mounting plate RSFP-X80 is used as a reference point.
- When using the reflective target RS183 or the mini prism RSMP380, these can be changed from horizontal to vertical orientation and vice versa. This permits surveying from almost anywhere on a 360° circle using the same measuring point.



Products with tilting axis height 45 mm

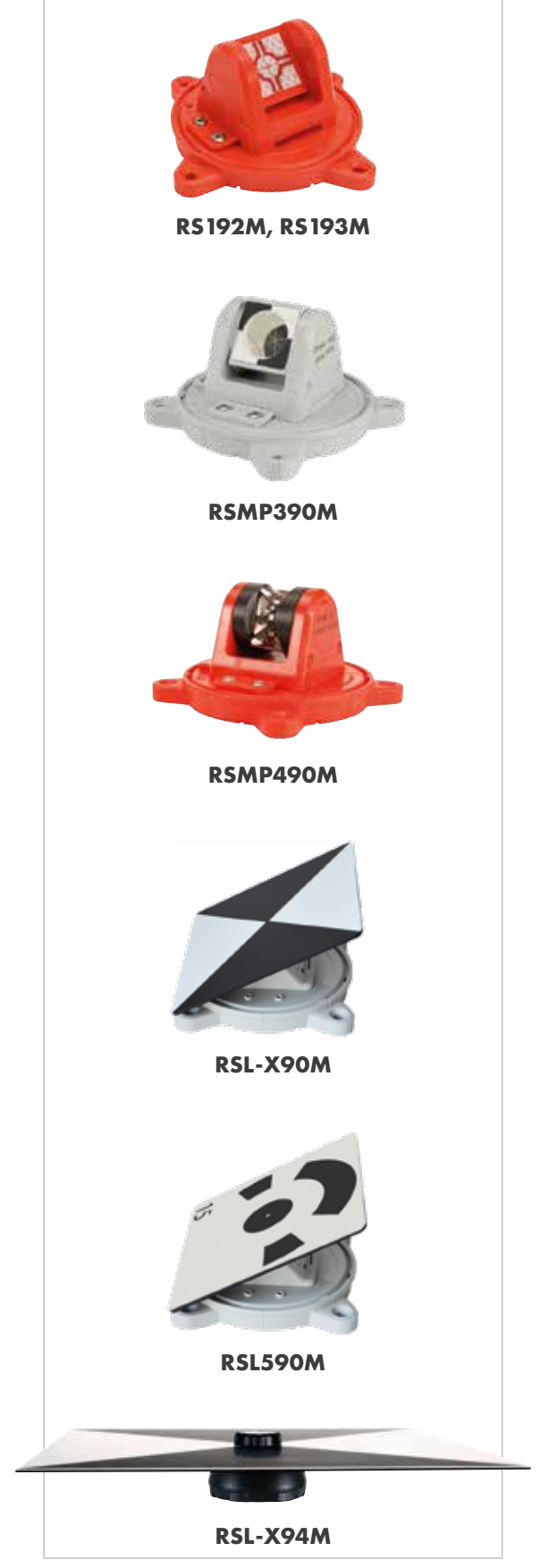

Fixed Point System RSFP-X90

Create fixed points quickly, easily and permanently – a unique system with multiple options



COMING SOON

Using the correct offset, the surveyor always obtains the same survey point or the same XYZ coordinates.

* Different country versions QR codes lead to respective application films on our YouTube channel

Products with tilting axis height 100 mm



Fixed Point System RSFP-X90 for all RS products with magnetic base

One reference point for all instruments:
Total stations, robotic total stations, scanners, drones, Lidar, SLAM, Mobile Mapping, GPS and GNSS!



Exceptional solutions make this system to a highlight in the survey field

- Depending on the instruments, accuracies of ± 1 mm are possible
- The fixed point system RSFP-X90 to RSFP-X99 is made of special stainless steel which reacts to magnets
- Magnets in the base plate hold various products exactly on the same point
- For repeat surveys, the resumption point RSFP-X90 is much appreciated, as it is almost invisible to passers-by, e.g. on bridges or façades.
- On building sites, the resumption point RSFP-X90 is used as a reference point
- Perfect for BIM, for surveys with scanners Scanner, Lidar or SLAM
- See the following pages for many more application examples

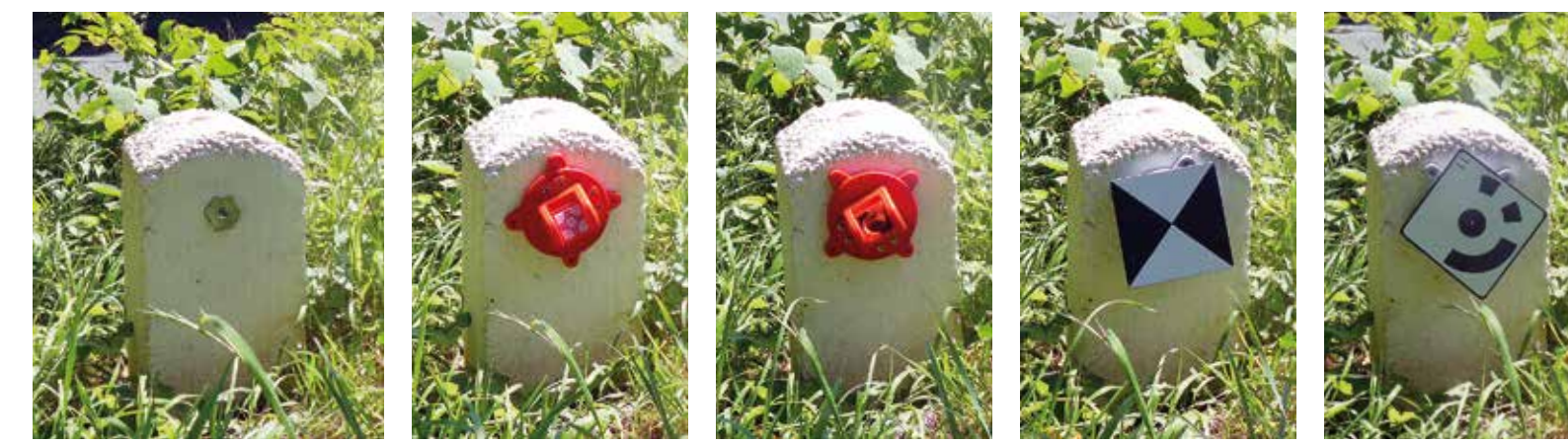

ONE FIXED POINT FOR ALL INSTRUMENTS
RSFP-X90

ONE FIXED
POINT FOR ALL
INSTRUMENTS

RSFP-X90

Products from our system

One fixed point for all instruments

RSFP-X90 fixed point – the best-known fixed point from this series

Fixed Point for all RS products with magnetic base. When using products with the same tilting axis height the reference point always remains exactly the same!



RSFP-X90-1, RSFP-X90-3 adapter

RSFP-X90 fixed point as separate version with a 5/8" (RSFP-X90-1) or 3/8" (RSFP-X90-3) female thread, when used with a tripod with 5/8" or 3/8" UNC threaded rod.



RSFP-X90-2 adapter

RSFP-X90 fixed point as separate version with a 5/8" male thread, when used with a tripod with 5/8" UNC threaded rod or in combination with the RSA-5/8-1 adapter.



RSPC90M cover

The RSPC90M protection cap protects the RSFP-X90 series reference points from soiling and weather effects such as ice and snow. Thanks to the magnetic lid, the protection cap can be removed from or placed on the reference point with a flick of the wrist.

For using reference points on the ground, the protection caps have a cross printed on them, so surveyors can easily position themselves over a reference point.

When using the RSFP-X90 reference points on walls and façades, the cross on the protection cap is used as reference points for SLAM and Lidar. Caution: you need to plan for an offset here!

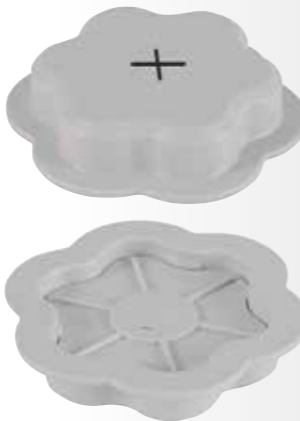

ONE FIXED
POINT FOR ALL
INSTRUMENTS

RSFP-X90

Products from our system

One fixed point for all instruments

RSFP-X90-5 adapter

In combination with Leica bolts there is the RSFP-X90-5 adapter, enabling all our products with a magnetic base to be easily attached to any Leica bolt.

COMING
SOON



RSFP-X99-5 adapter

In combination with Leica bolts there is also the RSFP-X99-5 adapter. If greater magnetic adhesion to the adapter is desired or required, we recommend this version (e.g. in tunnels).

COMING
SOON



RSFP-X90-20, RSFP-X90-21 adapter

Fixed point RSFP-X90-20 and RSFP-X90-21 with heavy duty anchor.

For quick and safe mounting of reference points on rocks, difficult surfaces or on historic buildings in the mortar joint.

Lengths 70 mm (RSFP-X90-20), 105 mm (RSFP-X90-21)
Borehole of Ø 10 mm)



RSFP-X99-20, RSFP-X99-21 adapter

Fixed point RSFP-X99-20 and RSFP-X99-21 with heavy duty anchor.

If greater magnetic adhesion to the adapter is desired or required, we recommend this version.

Lengths 70 mm (RSFP-X99-20), 105 mm (RSFP-X99-21)
Borehole of Ø 10 mm)



ONE FIXED
POINT FOR ALL
INSTRUMENTS

RSFP-X90

Products from our system

One fixed point for all instruments

RSFP-X90-25, RSFP-X90-26 adapter

RSFP-X90 fixed point for clamping points or pipes of \varnothing 22-24 mm (RSFP-X90-25) and \varnothing 27-29 mm (RSFP-X90-26), reusable

It has never been easier to create fixed points on construction site.

RSFP-X99-25, RSFP-X99-26 adapter

RSFP-X99 fixed point for clamping points or pipes of \varnothing 22-24 mm (RSFP-X99-25) and \varnothing 27-29 mm (RSFP-X99-26), reusable

If greater magnetic adhesion to the adapter is desired or required, we recommend this version.

RSFP-X90-30 to 39* adapter

Power socket adapter – smart solution for reference points inside

*available in different country versions

Digital 3D surveys are standard nowadays, and often one of the challenges is installing reference points in occupied areas so they are not visible.

We have developed these products precisely for this purpose.

In keeping with our "One reference point for all instruments" system, you can now use any socket as a reference point for all instruments. Take a picture of the socket used and you can recreate exactly the same survey point even after a long period of time without leaving a trace.

Suitable for this system and for the 3D survey, our suction cup and floor stand.



Products from our system

One fixed point for all instruments

Suction Cup RSSV-X90

Version \varnothing 120 mm for all RS products with magnetic base

For all glass surfaces and smooth surfaces, inside and outside.

Its pump function allows the suction cup to be firmly attached to the surface. Simple and quick installation – with no gluing or drilling required – is so guaranteed.

The perfect accessory for the 3D survey: suction cup RSSV-X90, power socket adapter RSFP-X90-30* and floor stand RSFP-X98.

Suction Cup RSSV-X99

If greater magnetic adhesion to the adapter is desired or required, we recommend this version.

RSFP-X98 Floor Stand

The RSFP-X98 floor stand is used on construction projects to establish reference points when neighbouring buildings or other objects are missing. For this purpose, the floor stand is pressed into soil, the foundation course or into the first concrete to flow on the construction site and is used as a temporary solution for reference points.

Another smart application is the use as a short-term reference point – unfold, set up, put on a target or prism, done.

The floor stand has a small hole in the centre so it can be positioned over an existing survey point.

A practical accessory that takes up hardly any space.



Products from our system

One fixed point for all instruments

Fixed Point RSFP-X99, RSFP-X99-11+12

For quick fixing on difficult substrates using adhesive, there is the RSFP-X99 support plate. In addition, the stainless steel support plate for magnets provides significantly more adhesion for all our products with a corresponding base plate.

As a long-term solution for monitoring on steel structures, these parts can also be welded on.

Anchor sleeves with a DW15 threaded rod are frequently used on many construction sites and in tunnels. To avoid tedious drilling or to create reference points that nobody can move, we have developed the RSFP-X99-11 adapter. This can be screwed into the existing anchor sleeves. Depending on the target or prism used, a reference point is created quickly for total stations, scanners, drones, SLAM or mobile mapping.

If a reference point is to be created by drilling for a long period of time and on difficult ground, we recommend the RSFP-X99-12 fixed point with a 160 mm long DW15 thread.

Adapter-Set RSFP-X90-S40

The adapters can be easily attached to one of the magnetic bases. The parts are automatically positioned correctly by the RSFP-X90 reference point (flower) and held by the magnets on the base plate.

Depending on the attachment, the user has now the following possibilities:

- Control measurements of inside and outside corners
- Control measurements at recesses or at the edge of the ceiling
- Measurements on pillars – direct measurements can be taken on bevelled edges at the vertex!
- Transfer heights around the corner with marking attachment
- Measure of position and heights of corner blocks quickly and precisely when bonding clay blocks



Expected to be available from October 2023



Accessories

Adapters RSA-X80g-1 and RSA-X80g-2

A plug system is built into the base plate of many of our products as standard, enabling a wide variety of connections between the products.

The RSA-X80g-1 angled adapter and the RSA-X80g-2 adapter enable other combinations that are very helpful for surveying, such as:

- RS mini prisms stacked on top of each other for measurements from bottom to top, e. g. from level 0 to level XY
- RS mini prisms with RS scanner targets
- RS mini prisms with RS ground control targets
- RS mini prisms with RS SLAM targets
- RS mini prisms with RS mobile mapping targets

**The RS surveying accessory system:
High precision with countless options.**

Adapter with 5/8" thread RSA-5/8-1

With the adapter RSA-5/8-1, many further combinations can also be easily mounted on a tribrach.

See figure below right.

When mounting the scanner targets RSL420M and RSL422M over a prism, the adapter RSA-5/8-1 is additionally used as a connecting piece.

In Combination

Thanks to our extensive RS surveying accessory system, different surveying instruments can use the same reference point or measurements can be made using various surveying instruments with exactly the same survey point.

The illustration on the right shows one of the various combinations that are possible thanks to the clever plug-in system and the ever growing range of accessories available at Rothbucher Systems.

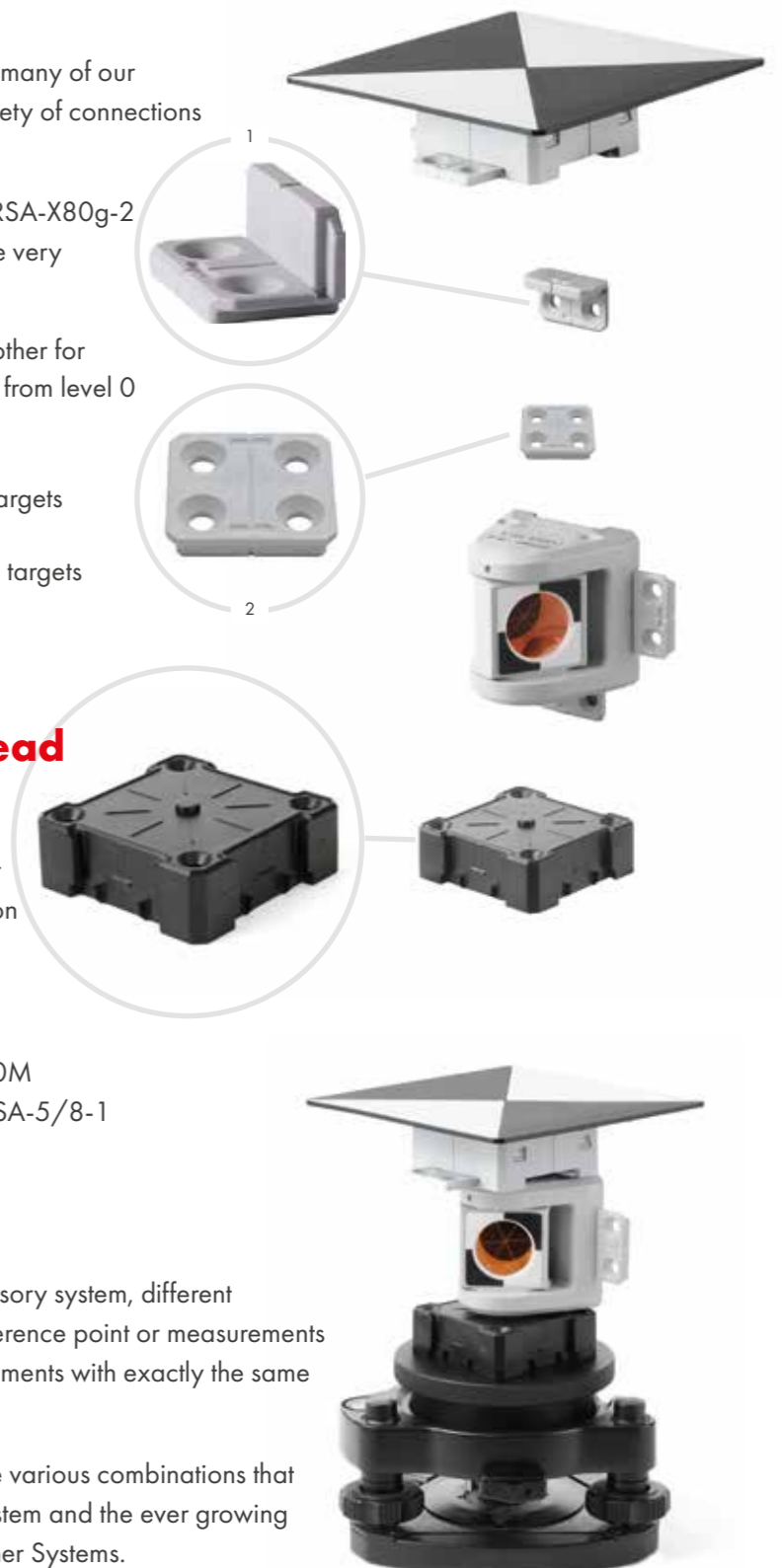

Accessories



Protection Cap RSPC20 and RSPC20M*

These protection caps protect prisms and reflective targets from the weather and soiling. For points that are hard to reach, on a tunnel roof, for example, we offer the magnetic version.

The metal cube RSPC50 can be screwed onto a prism pole with 5/8" thread (see illustration below). This enables the protection cap to be removed from and fitted over the prism at a height of 3-4 meters.

RSPC20/RSPC20M* for RS183,
RSMP280, RSMP380, RSMP480



*magnetic

Metal Cube RSPC50 with 5/8" Female Thread

With its 5/8" thread, the metal cube RSPC50 can be screwed onto a prism pole.

The magnetic protection cap RSPC20M* can thereby be easily fitted over and removed from the plastic case of the prisms, even from difficult positions, and refitted at any time.



Construction Glue with high grab RSMK-FIX

- High-performance mounting adhesive with instant initial adhesion
- Isocyanate- and silicone-free
- Permanently elastic and suitable for a wide range of uses
- Odourless
- RSMK-FIX is suitable for all products from Rothbucher Systems
- Can be used in any current pistol applicator
- A good applicator is recommended



Suitcase-Sets with Prisms or Reflective Targets

Ideal for construction surveying, staking out or measuring



NEW

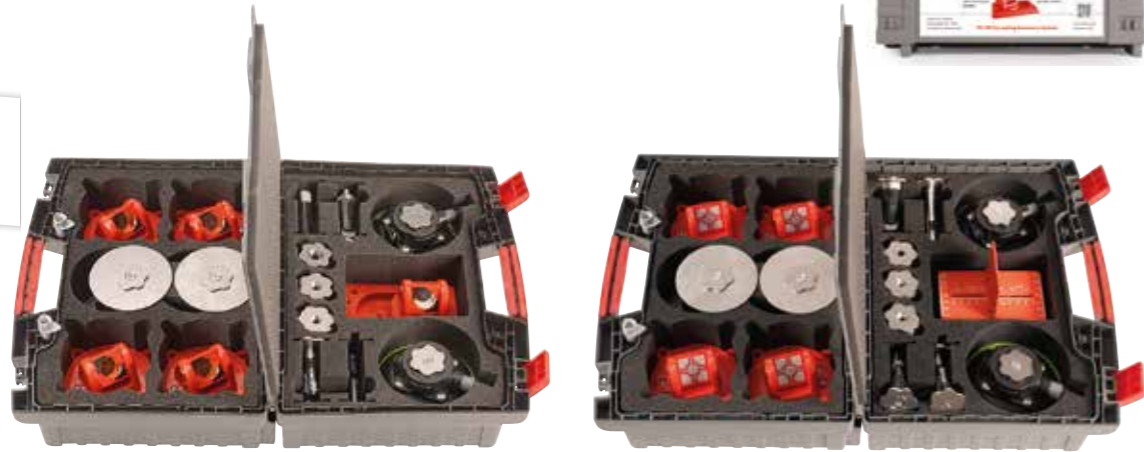

Fig. KS1-390M+
Metrics: B 390 mm x H 310 mm x T 200 mm
Weight: 6.3 kg

Fig. KS1-193M+
Metrics: B 390 mm x H 310 mm x T 200 mm
Weight: 6.3 kg

Compactly and safely packaged, practical and quickly to hand – our suitcase sets, the ideal companion: Everywhere.

Suitcase KS1-390M+ with:

- 4 Mini Prisms RSMP390M
- **optional** 1 Stake Out Aid for Robotic Total Stations RS150M

Accessories

- 2 Suction Cups RSSV-X90
- 2 Adapters RSFP-X90-1
- 2 Adapters RSFP-X90-2
- 30 Fixed Points RSFP-X90
- 4 Fixed Points RSFP-X90-20
- 2 Fixed Points RSFP-X90-21
- 2 Fixed Points RSFP-X90-25
- 2 Fixed Points RSFP-X90-26
- 4 Fixed Points RSFP-X99-11

Suitcase KS1-193M+ with:

- 4 Reflective Targets RS192M or RS193M
- 1 Stake Out Aid RS96

Accessories

- 2 Suction Cups RSSV-X90
- 2 Adapters RSFP-X90-1
- 2 Adapters RSFP-X90-2
- 30 Fixed Points RSFP-X90
- 4 Fixed Points RSFP-X90-20
- 2 Fixed Points RSFP-X90-21
- 2 Fixed Points RSFP-X90-25
- 2 Fixed Points RSFP-X90-26
- 4 Fixed Points RSFP-X99-11

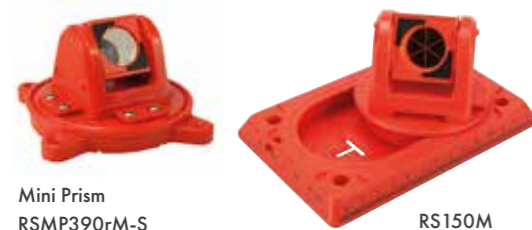

Mini Prism
RSMP390rM-S

RS150M

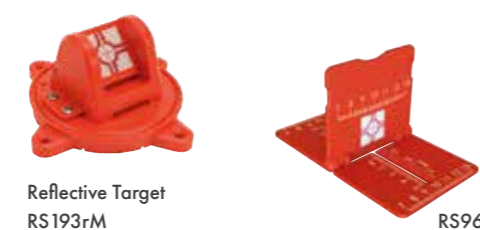

Reflective Target
RS193rM

RS96

Suitcase-Sets with Laser Scanner- or SLAM Targets

Ideal for 3D inside and outside measurements



NEW

Fig. (left) KS2 available for RSL420M, RSL422M, RSL452M
Metrics: B 390 mm x H 310 mm x T 200 mm
Weight: 4.5 kg

Fig. (right) KS2-2 available for RSL420M, RSL422M, RSL452M
Metrics: B 500 mm x H 420 mm x T 225 mm
Weight: 9 kg

Suitcase sets with laser scanner- or SLAM targets – perfectly coordinated equipment packaged to save space.

Suitcase KS2-422M or KS2-422M with:

- 6 Laser Scanner Targets RSL420M or RSL422M
- 1 Mini Prism RSMP395M

Accessories

- 30 Fixed Points RSFP-X90
- 4 Fixed Points for power sockets RSFP-X90-30*

Suitcase KS2-452M with:

- 6 Laser Scanner- and SLAM Targets RSL452M
- 1 Mini Prism RSMP395M

Accessories

- 30 Fixed Points RSFP-X90
- 4 Fixed Points for power sockets RSFP-X90-30*

Suitcase KS2-420M or KS2-422M-2 with:

- 4 Laser Scanner Targets RSL420M or RSL422M
- 1 Mini Prism RSMP395M

Accessories

- 50 Fixed Points RSFP-X90
- 4 Fixed Points for power sockets RSFP-X90-30*
- 2 Suction Cups RSSV-X90
- 3 Floor Stands RSFP-X98

Suitcase KS2-452M-2 with:

- 4 Laser Scanner- and SLAM Targets RSL452M
- 1 Mini Prism RSMP395M

Accessories

- 50 Fixed Points RSFP-X90
- 4 Fixed Points for power sockets RSFP-X90-30*
- 2 Suction Cups RSSV-X90
- 3 Floor Stands RSFP-X98



RSL420M / RSL422M

RSL452M

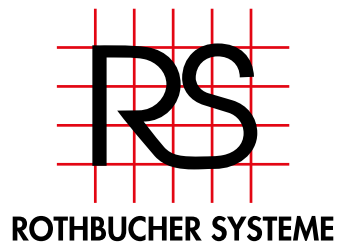

ROTHBUCHER SYSTEME



The RS Surveying Accessory System Proven millionfold – in use worldwide

Request our price list

Rothbucher Systeme
Reichenhaller Str. 109A
D-83435 Bad Reichenhall
www.smart-targets.com

Phone +49 (0) 8651 2749
Fax +49 (0) 8651 3090
Cell +49 (0) 171 7314961
info@smart-targets.com

