



Dave Whites

SitePro™



Baseline Equipment
Company®

Serving field professionals everywhere.



QUICK GUIDE

model
27-4852-16

COLUMN CLAMP

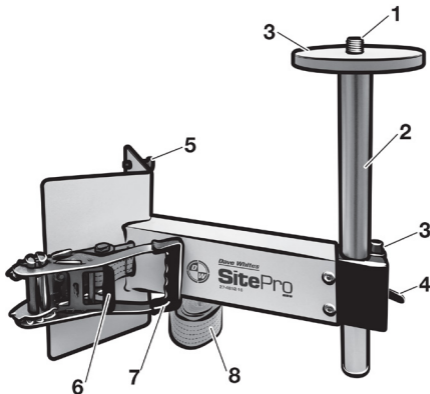

FEATURES AT A GLANCE

1. 5/8-11 Thread
2. Adjustable Column
3. Rubber Washer -
Protects Finger
4. Locking Lever
5. Fine Adjustment Bolt
6. Ratchet Clamp Release
7. Ratchet Clamp Handle
8. Heavy-Duty Strap

INTENDED USE

The column clamp is intended to mount to structural columns for stability and support for heavy instruments with 5/8-11 threads

	27-4852-16
Mounting	
Platform	6-in Flat
Thread	5/8-11
Vertical Adjustment	12" (30cm) Height
Distance From Centerline	15-in (38cm)
Strap	Heavy-duty 2" (5.08cm) nylon, 10-ft (3.05m) length
Material	Structural Aluminum with stainless steel hardware
Load Rating	Up to 2,200 lb (1,000 kg)
Weighs	13.8 lb (6.25 kg)

Specifications and product information are subject to change without notification.

Includes: Column system (with ratchet and strap), mounting platform with 5/8-11 stud, and adjustable column.

©2018 Dave White's SitePro LLC
Lafayette, IN USA

www.baselineequipment.com